



ASW05kH/06kH/08kH/10kH/12kH-T2

ASW05kH/06kH/08kH/10kH/12kH-T2-O

ASW08kH/10kH/12kH-T3

ASW08kH/10kH/12kH-T3-O

# Three phase hybrid inverter

## User Manual

## Contents

1	General information .....	3	8.2	Download and install.....	60
1.1	About this document.....	3	8.3	Create an account.....	60
1.2	Product validity.....	3	8.4	Create a plant .....	62
1.3	Target group.....	3	8.5	Setting parameters .....	68
1.4	Symbols .....	4	8.6	Parallel parameter setting and using.....	81
2	Safety.....	5	8.7	Split phase control .....	84
2.1	Intended use .....	5	8.8	Activated Arc-fault Circuit Interrupter (AFCI) .....	84
2.2	Important safety instructions.....	5	9	Decommissioning the product .....	87
2.3	Symbols on the label.....	8	9.1	Disconnecting the inverter from voltage sources.....	87
3	Unpacking and storage.....	9	9.2	Dismantling the inverter .....	89
3.1	Scope of delivery .....	9	10	Technical data .....	90
3.2	Product storage .....	10	10.1	ASW05kH/06kH/08kH/10kH/12kH-T2 ....	90
4	Inverter overview.....	11	10.2	ASW05kH/06kH/08kH/10kH/12kH-T2-O	93
4.1	Product description.....	11	10.3	ASW08kH/10kH/12kH-T3.....	96
4.2	Dimensions.....	11	10.4	ASW08kH/10kH/12kH-T3-O .....	99
4.3	LED indicator .....	12	10.5	General data .....	102
4.4	Supported grid types.....	12	10.6	Protective function.....	103
4.5	Interfaces and functions .....	13	11	Troubleshooting .....	104
4.6	Basic system solution .....	16	12	Maintenance .....	106
4.7	Energy Management.....	19	12.1	Cleaning the contacts of the DC switch ..	106
4.8	Parallel System .....	24	12.2	Cleaning air inlet and outlet .....	106
5	Mounting .....	27	13	Recycling and disposal.....	107
5.1	Requirements for mounting.....	27	14	EU declaration of conformity .....	107
5.2	Taking out and moving the product .....	28	15	Service and warranty .....	107
5.3	Mounting.....	29	16	Contact.....	108
6	Electrical connection.....	31			
6.1	Connection port description .....	31			
6.2	Connecting additional grounding.....	32			
6.3	Grid cable connection .....	33			
6.4	EPS Load cable connection .....	38			
6.5	DC connection.....	42			
6.6	Battery connection .....	49			
6.7	Ai-Dongle connection .....	51			
6.8	Communication equipment connection.....	53			
7	Commissioning and operating .....	59			
7.1	Inspection before commissioning .....	59			
7.2	Commissioning procedure.....	59			
8	Solplanet APP.....	60			
8.1	Brief introduction.....	60			

# 1 General information

## 1.1 About this document

This document describes the mounting, installation, commissioning, configuration, operation, troubleshooting and decommissioning of the product as well as the operation of the product user interface.

You will find the latest version of this document and further information on the product in PDF format at [www.solplanet.net](http://www.solplanet.net).

It is recommended that this document is stored in an appropriate location and be available at all times.

## 1.2 Product validity

This document is valid for the following models:

- ASW05kH/06kH/08kH/10kH/12kH-T2
- ASW05kH/06kH/08kH/10kH/12kH-T2-O
- ASW08kH/10kH/12kH-T3
- ASW08kH/10kH/12kH-T3-O



For Australia market, this document is valid for the following models:

- ASW05kH-T2
- ASW05kH-T2-O
- ASW08kH/10kH/12kH-T3
- ASW08kH/10kH/12kH-T3-O

## 1.3 Target group

This document is intended for qualified persons who must perform the tasks exactly as described in this user manual.

All installation work must be performed by appropriately trained and qualified persons.

Qualified persons must possess the following skills:

- Knowledge of how an inverter works and is operated.
- Knowledge of how batteries work and are operated.
- Training in how to deal with the dangers and risks associated with installing, repairing and using electrical devices, batteries and installations.
- Training in the installation and commissioning of electrical devices.
- Knowledge of all applicable laws, standards and directives.
- Knowledge of and compliance with this document and all safety information.

## 1.4 Symbols

### **DANGER**

Indicates a hazardous situation which, if not avoided, will result in death or serious injury.

### **WARNING**

Indicates a hazardous situation which, if not avoided, could result in death or serious injury.

### **CAUTION**

Indicates a hazardous situation which, if not avoided, could result in minor or moderate injury.

### **NOTICE**

Indicates a situation which, if not avoided, can result in property damage.



Information that is important for a specific topic or goal, however not related to safety.

## 2 Safety

### 2.1 Intended use

- The product is a transformerless hybrid inverter with 2 or 3 MPP trackers and a battery connection that feeds the direct current of the PV array into the connected battery or converts it to grid-compliant three-phase current and then feeds it into the utility grid. The product also can convert the DC current supplied by the battery into grid-compliant three-phase current. The product also can convert the AC current supplied by the grid into battery current.
- The product has a backup function that can continue to supply selected circuits with power from the battery or PV system in the event of a grid fault.
- The product also can convert the direct current supplied by the battery into grid-compliant three-phase current. The product is intended for indoor and outdoor applications.
- The product must only be connected with PV modules of protection class II (in accordance with IEC 61730, application class A). Do not connect any sources of energy other than PV modules and batteries to the product.
- The product is not equipped with an integrated transformer and therefore has no galvanic isolation. The product must not be operated with PV modules which require functional grounding of either the positive or negative PV conductors. This can cause the product to be irreparably damaged. The product may be operated with PV modules with frames that require protective earthing.
- All components must remain within their permitted operating ranges and their installation requirements at all times.
- Use the product only in accordance with the information provided in the user manual and with the locally applicable standards and directives. Any other application may cause personal injury or damage to property.
- The product must only be operated in connection with an intrinsically safe lithium-ion battery approved by AISWEI. The entire battery voltage range must be completely within the permissible input voltage range of the product.
- The product must only be used in countries for which it is approved by AISWEI and the grid operator.
- Knowledge of all applicable laws, standards and directives.
- Knowledge of and compliance with this document and all safety information.
- The type label must be permanently attached to the product and must be in a legible condition.
- This document does not replace any regional, state, provincial, federal or national laws, regulations or standards that apply to the installation, electrical safety and use of the product.

### 2.2 Important safety instructions

The product has been designed and tested strictly according to the international safety requirements. As with all electrical or electronical devices, there are residual risks despite careful construction. To prevent personal injury and property damage and to ensure long-term operation of the product, read this section carefully and observe all safety information at all times.

#### **DANGER**

Danger to life due to high voltages of the PV array or the battery !

The DC cables connected to the battery or the PV array may be live. Touching the DC conductors or the live components can cause lethal electric shocks. If you disconnect the DC connectors from the product under load, an electric arc may occur leading to electric shock and burns.

Do not touch non-insulated cable ends.

Do not touch the DC conductors.

Do not touch any live components of the product.

Do not open the product.

Observe all safety information of the battery manufacturer.

All work on the product must only be carried out by qualified personnel who have read and fully understood all safety information contained in this document and the user manual.

Disconnect the product from all voltage and energy sources and ensure it cannot be reconnected before working on the product.

Wear suitable personal protective equipment for all work on the product.

## ***DANGER***

Danger to life due to electric shock when touching live components in backup mode !

Even if the AC breaker and the PV switch of the inverter are disconnected, the parts of the system may still be live when the battery is switched on due to backup mode.

Do not open the product.

Disconnect the product from all voltage and energy sources and ensure it can not be reconnected before working on the product.

## ***DANGER***

Danger to life due to fire or explosion when batteries are fully discharged !

Danger to life due to fire or explosion when batteries are fully discharged.

Make sure that the battery is not fully discharged before commissioning the system.

Contact the battery manufacturer for further proceedings if the battery is fully discharged.

## ***DANGER***

Danger to life due to burns caused by electric arcs through short-circuit currents !

Short-circuit currents in the battery can cause heat accumulation and electric arcs if the battery is short circuited or wrongly installed. Heat accumulation and electric arcs may result in lethal injuries due to burns.

Disconnect the battery from all voltages sources prior to performing any work on the battery.

Only use properly insulated tools to prevent accidental electric shock or short circuits during installation.

Observe all safety information of the battery manufacturer.

## ***DANGER***

Danger to life due to electric shock when touching live system components in case of a ground fault !

If a ground fault occurs, parts of the system may still be live. Touching live parts and cables may result in death or lethal injuries due to electric shock.

Disconnect the product from voltage and energy sources and ensure it cannot be reconnected before working on the device.

Only touch the cables of the PV modules on their insulation.

Do not touch any parts of the substructure or frame of the PV array.

Do not connect PV strings with ground faults to the product.

## **WARNING**

Danger to life due to electric shock from destruction of the measuring device due to overvoltage!

Overvoltage can damage a measuring device and result in voltage being present in the enclosure of the measuring device.

Touching the live enclosure of the measuring device results in death or lethal injuries due to electric shock.

Only use measuring devices with the measurement span higher than the DC input voltage range

## **CAUTION**

Risk of burns due to high temperature!

Some parts of the enclosure can become hot during operation.

During operation, do not touch any parts other than the enclosure lid of the product.

## **CAUTION**

Risk of injury due to weight of product!

Injuries may result if the product is lifted incorrectly or dropped while being transported or mounted.

Transport and lift the product carefully. Take the weight of the product into account.

Wear suitable personal protective equipment for all work on the product.

## **NOTICE**

Damage to the inverter due to electrostatic discharge.

Internal components of the inverter can be irreparably damaged by electrostatic discharge.

Ground yourself before touching any component.



The country grid code set must be set correctly.

If you select a country grid code set which is not valid for your country and purpose, it can cause a disturbance in the PV system and lead to problems with the grid operator. When selecting the country grid code set, you must always observe the locally applicable standards and directives as well as the properties of the PV system (e.g., PV system size, grid-connection point).

If you are not sure which standards and directives are valid for your country or purpose, contact the grid operator.

## 2.3 Symbols on the label

---



**Beware of a danger zone!**

This symbol indicates that the product must be additionally grounded if additional grounding or equipotential bonding is required at the installation site.

---



**Beware of high voltage and operating current!**

The product operates at a high voltage and current. Work on the product must only be carried out by skilled and authorized personnel.

---



**Beware of hot surfaces!**

The product can get hot during operation. Avoid contact during operation.

---



**WEEE Designation**

Do not dispose of the product together with household waste. Dispose the product in accordance with local disposal regulations for electronic waste

---



**CE marking**

The product complies with the requirements of the applicable EU directives.

---



**Certification mark**

The product has been tested by T89 and got the Tuality certification mark.

---



**CE marking**

The product complies with the requirements of the applicable EU directives.

---



**CaSactor discharge**

Danger to life due to high voltages in the inverter. Do not touch live parts for 5 minutes after disconnection from the power sources.

---



**Observe the documentation**

Read and understand all documentation supplied with the product.

---



## 3 Unpacking and storage

### 3.1 Scope of delivery

Check the scope of delivery for completeness and any visible external damage. Contact your distributor if the scope of delivery is incomplete or damaged.

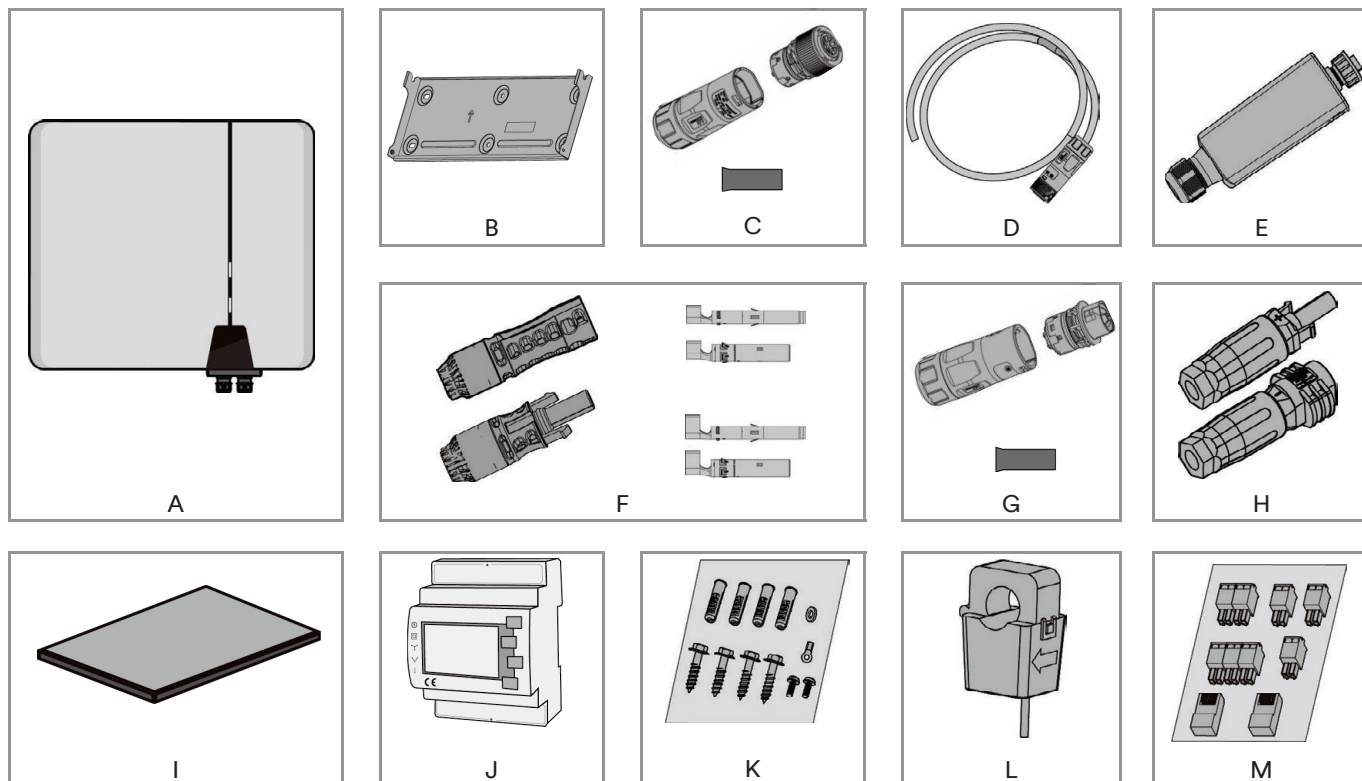

Object	Description	Quantity	
A	Inverter	1	
B	Wall Bracket	1	
C	AC connector	1	
	Terminal	5	
D	AC connector (10-12kH)	1	
E	Communication device Ai-Dongle(WLAN/LAN)	1	
F	Battery connector	MC4-Evo stor, positive and negative	1
	Crimp contact	6mm <sup>2</sup> PV-KBT4-EVO ST/6II Male PV-KST4-EVO ST/6II Female	1
		10mm <sup>2</sup> PV-KBT4-EVO ST/10II Male PV-KST4-EVO ST/10II Female	1
G	EPS Load connector	ASW05-12kH-T2-O	0

		ASW08-12kH-T3-O	
		ASW05-12kH-T2 ASW08-12kH-T3	1
	Terminal	ASW05-12kH-T2-O ASW08-12kH-T3-O	0
		ASW05-12kH-T2 ASW08-12kH-T3	5
H	DC connector	ASW05-12kH-T2 ASW05-12kH-T2-O	2
		ASW08-12kH-T3 ASW08-12kH-T3-O	3
I	Document		1
J	Smart meter		1
K	Fastener package		1
L	External CT		3
M	Communication terminal package		1

## 3.2 Product storage

Suitable storage is required if the inverter is not installed immediately:

- Store the inverter in the original packing case.
- The storage temperature must be between -30°C to +70°C, and the storage relative humidity must be between 0 and 100%, non-condensing.
- The packing with the inverter shall not be tilted or inverted.
- The product must be fully inspected and tested by professionals(Refer to section 1.3) before it can be put into operation, if it has been stored for half a year or more.

## 4 Inverter overview

### 4.1 Product description

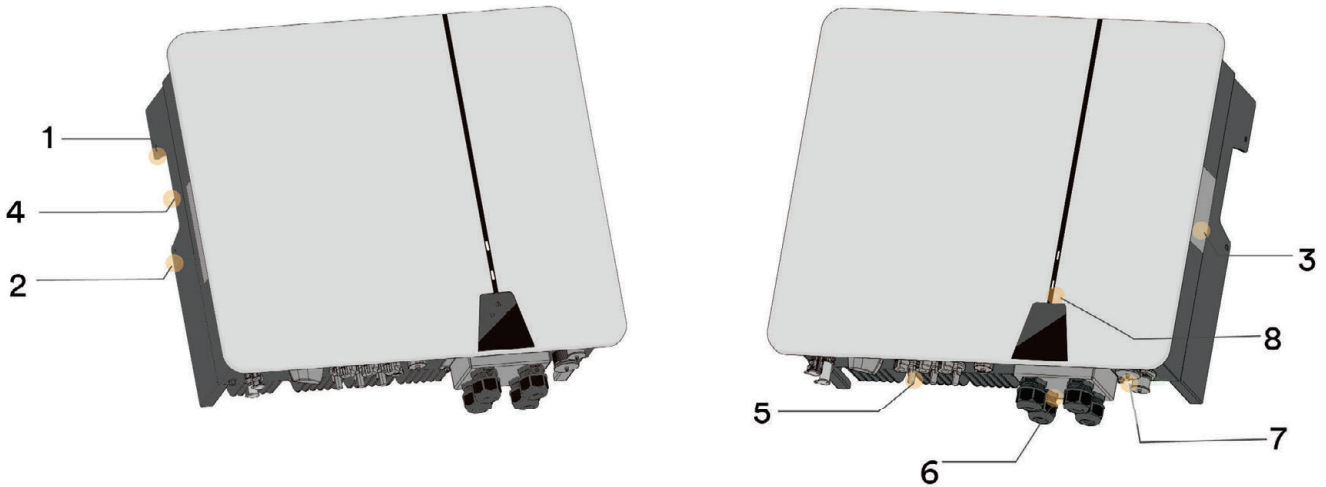
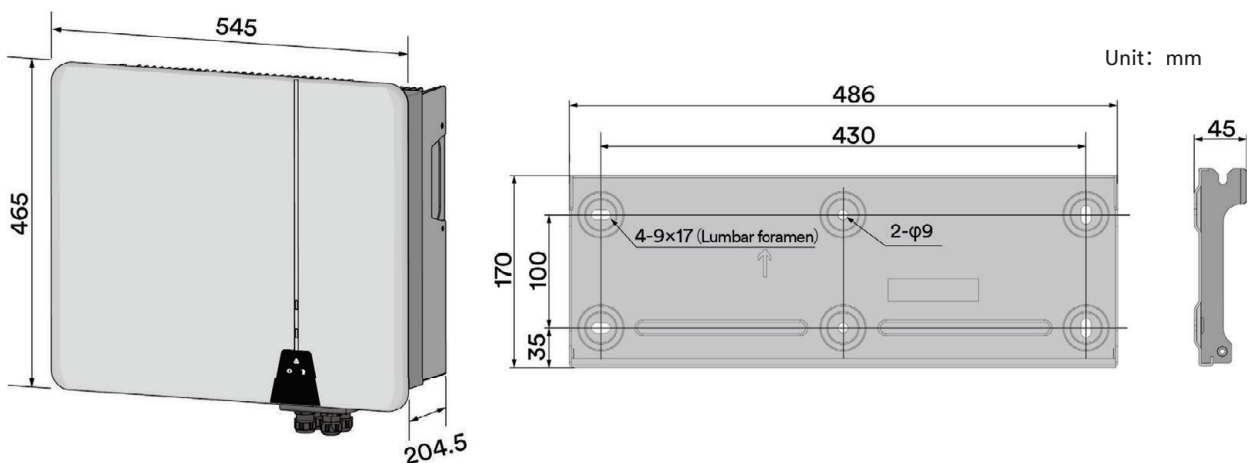





















Figure shown here is for reference only. The actual product received may differ!

Object	Name	Description
1	Mounting ears	Two ears hang the inverter onto the mounting-bracket.
2	Inverter fixed point	Two points, used for the fixed connection between the inverter and the mounting-bracket.
3	Labels	Warning symbols, nameplate, and QR code.
4	Handles	Two handles, move the product and hang the inverter onto the mounting-bracket.
5	DC wiring area	DC switches, DC terminals and BAT terminals.
6	Communication wiring area	WIFI terminals and communication cover.
7	AC wiring area	GRID terminals and EPS Load terminals.
8	Display area	LED indicator and display panel.

### 4.2 Dimensions



## 4.3 LED indicator

Function	LED	Description
SOLAR	 Glowing	The product operates normally and the solar energy is available.
	 Flashing	The product is self-checking automatically, or the firmware is updating.
	 Off	The solar energy is not available.
BAT	 Glowing	The product operates normally and the battery energy is available.
	 Flashing	The product is self-checking automatically, or the firmware is updating, or the SOC of the battery is low.
	 Off	The battery energy is not available.
ERR	 Yellow Glowing	The communication with the Ai-Dongle has failed.
	 Yellow Flashing	There is a warning fault, the warning message and the corresponding event number will be displayed on the product user interface.
	 Red Glowing	There is an error fault. The Error message and the corresponding event number will be displayed on the product user interface.
	 Off	The product is operating normally.
EPS	 White Glowing	The EPS port of the product operates with the loads.
	 White Flashing	The EPS port of the product operates without the loads.
	 Red Glowing	The EPS port of the product has failed.
	 Red Flashing	The EPS port of the product operates with overload.
	 Off	The EPS port of the product stop operation.
GRID	 White Glowing	The product connects to the Grid and feeds the solar energy into the utility grid.
	 White Flashing	The product doesn't connect to the grid and operates as an off-grid mode.
	 Red Glowing	The product disconnects from the Grid due to a fault.
	 Off	The product stop operation.

For safety reasons, EPS LED white flash when there is no load or when the load power is low.

## 4.4 Supported grid types

The grid structures supported by the product is TN-S, TN-C, TN-C-S, TT, as shown in the figure below:

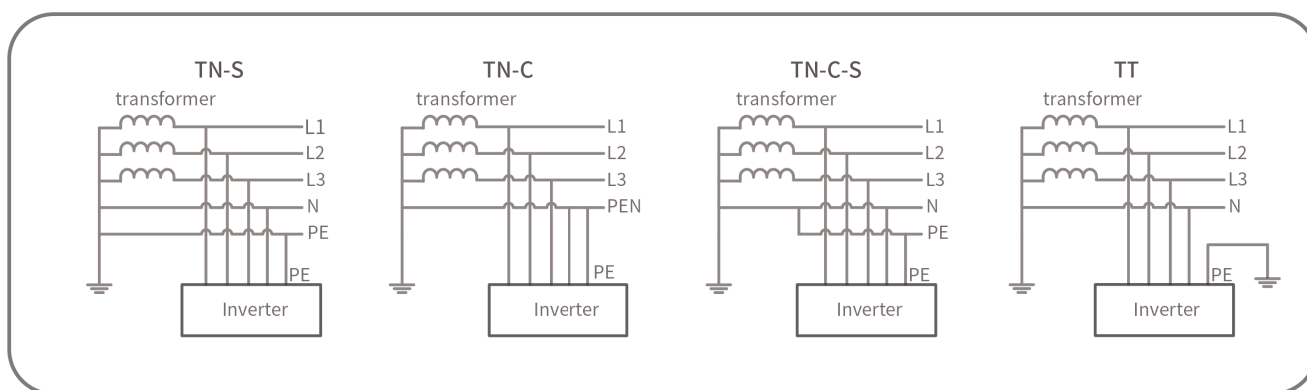

For the TT grid structure, the effective value of the voltage between the neutral wire and the ground wire must be less than 20V.

## 4.5 Interfaces and functions

The product is equipped with the following interfaces and functions:

### Ai-Dongle

The product is equipped with an Ai-Dongle as standard, which provides a user interface for configuring and monitoring the product. The Ai-Dongle can connect to the Internet via WLAN or the Ethernet cable. If you don't want to use Ai-Dongle, the Solplanet communication products or the third-party monitor device can be chosen.

### RS485 Interface

The product equipped with several RS485 interfaces. Some RS485 interfaces connected through RJ45 ports. Some RS485 interfaces connected through terminal block.

RJ45-1 and RJ45-2 ports (see section 6.8.1): Two RS485 interfaces used to the product parallel operation (see section 4.1). The monitoring information of all the slave inverters can exchange with the master inverter through the RS485 interfaces. And the master inverter transfers the monitoring information to Internet through the Ai-Dongle.

RJ45-3 port (see section 6.8.1): This RS485 interface used to connect the product to the third-party monitor device. If you don't want to use Ai-Dongle, the third-party monitor device can be used.

Terminal block 2 (see section 6.8.1): This RS485 interface (Pin1 and Pin2) used to connect the external smart meter. If the smart meter be chosen to replace the current transformer, the smart meter can connect to this RS485 interface.

### RS485/CAN (Controller Area Network) Interface

The product equipped with several RS485/CAN interfaces. The CAN interfaces and RS485 interfaces connected through one RJ45 ports.

RJ45-4 port (see section 6.8.1): This RS485/CAN interface used to connect the BMS (Battery Manage System) of the battery (see section 6.8.1). If the communication interface of the BMS is CAN interface, the pins for CAN interface can be chosen to connect. If the communication interface of the BMS is RS485 interface, the pins for RS485 interface can be chosen to connect.

RJ45-5 and RJ45-6 ports (see section 6.8.1): Two RS485/CAN interfaces used to the product parallel operation (see section 4.1). The control information can be exchanged between the master inverter and the slave inverter through the RS485/CAN interfaces. Both the pins for RS485 interface and CAN interface shall be chosen to connect.

## **Modbus RTU**

The product is equipped with a Modbus interface. If the third-party communication device also complies with AISWEI Modbus protocol, which can be connected to this product.

## **Export active power control**

The product is equipped with the export active power limit function, so as to meet the requirements of some national standards or grid standards for limiting the output power at the grid connection point. The export active power control solution measures the active power at the point where the customer's installation is connected to the distribution system (point of grid connection) and then uses this information to control the inverter's output active power in order to prevent the export active power to the distribution system from exceeding the agreed export capacity.

The product is delivered with the current transformers as standard. The current transformers can be used to measure the export active power. The communication of the current transformers can be connected to the product through RS485 (see section 6.8.1, Terminal 2). And the current transformer also can be replaced by the smart meter.

The smart meter that can be used with this product must be approved by AISWEI. For more information about the smart meter, please contact the service.

## **Multifunction Relay**

The product is equipped with two multifunction relays as standard. The multifunction relays can be configured for the operating mode used by a particular system. For more information, please contact AISWEI service.

## **Temperature Senser Interface**

The product is equipped with one temperature senser interface (see section 6.8.1). If the temperature of the battery need be monitored, the external senser can be connected.

## **The communication interface for external central grid protection device**

The product is equipped with one communication interface (see section 6.8.1) to connect the external central grid protection device. For more information, please contact with AISWEI service.

## **Inverter demand response modes (DRED)**

The product shall detect and initiate a response to all supported demand response commands according to the standard AS/NZS 4777.2.

The product only supports the demand response mode DRM 0. The interaction with demand response enabling device (DRED) can be connected to the terminal block 3 (see section 6.8.1). The Pin 5 and Pin 6 of the terminal block 3 represents the REF GEN/0 and COM LOAD/0.

## **Ripple control receiver interface**

The product is equipped with one interface to connect Ripple Control Receiver device (see section 6.8.1).

## **Current transformer interface**

The current transformers can be used to measure the export active power and control the export active power at the point of grid connection. The three current transformers can be connected to terminal block 4 (See section 6.8.1).

### **Back-up function**

The inverter is equipped with a back-up function which also called as an emergency power supply (EPS). The back-up function ensures that the inverter forms a three-phase back-up grid that uses energy from the battery and the PV system that is directly connected to the inverter to supply the critical load in the event of a utility grid failure.

In the event of a grid failure, the product disconnects from the grid. The product provides a standalone grid and the backup loads, which connect to EPS connector, continue to be supplied by the energy stored in the battery and the PV modules.

The charging of the battery is ensured by the existing PV system during back-up operation.

As soon as the utility grid is available again, the product will automatically connect to the grid and the loads are supplied with energy from the utility grid.

### **Earth fault alarm**

This product complies with IEC 62109-2 clause 13.9 for earth fault alarm monitoring. If an Earth Fault Alarm occurs, the red color LED indicator will light up. At the same time, the error code 38 will be sent to the Solplanet Cloud.

### **Arc-fault Circuit Interrupter (AFCI) function**

The arc-fault circuit interrupter (AFCI) integrated in Solplanet's inverter selects a specific medium frequency band to detect genuine DC arcs. When the arc-fault circuit interrupter (AFCI) is enabled in the inverter, the PV system continuously monitors for electric arcs. If a current phenomenon typical of electric arcs is detected, the inverter immediately stops the feed-in operation and reports the event. This interruption of the feed-in operation stops the current flow in the DC circuit, effectively extinguishing the electric arc.

## 4.6 Basic system solution

The product is a high-quality inverter which can convert solar energy to AC energy and store energy into battery. The product can be used to optimize self-consumption, store in the battery for future use or feed into public grid.

The basic application of this product as follow:

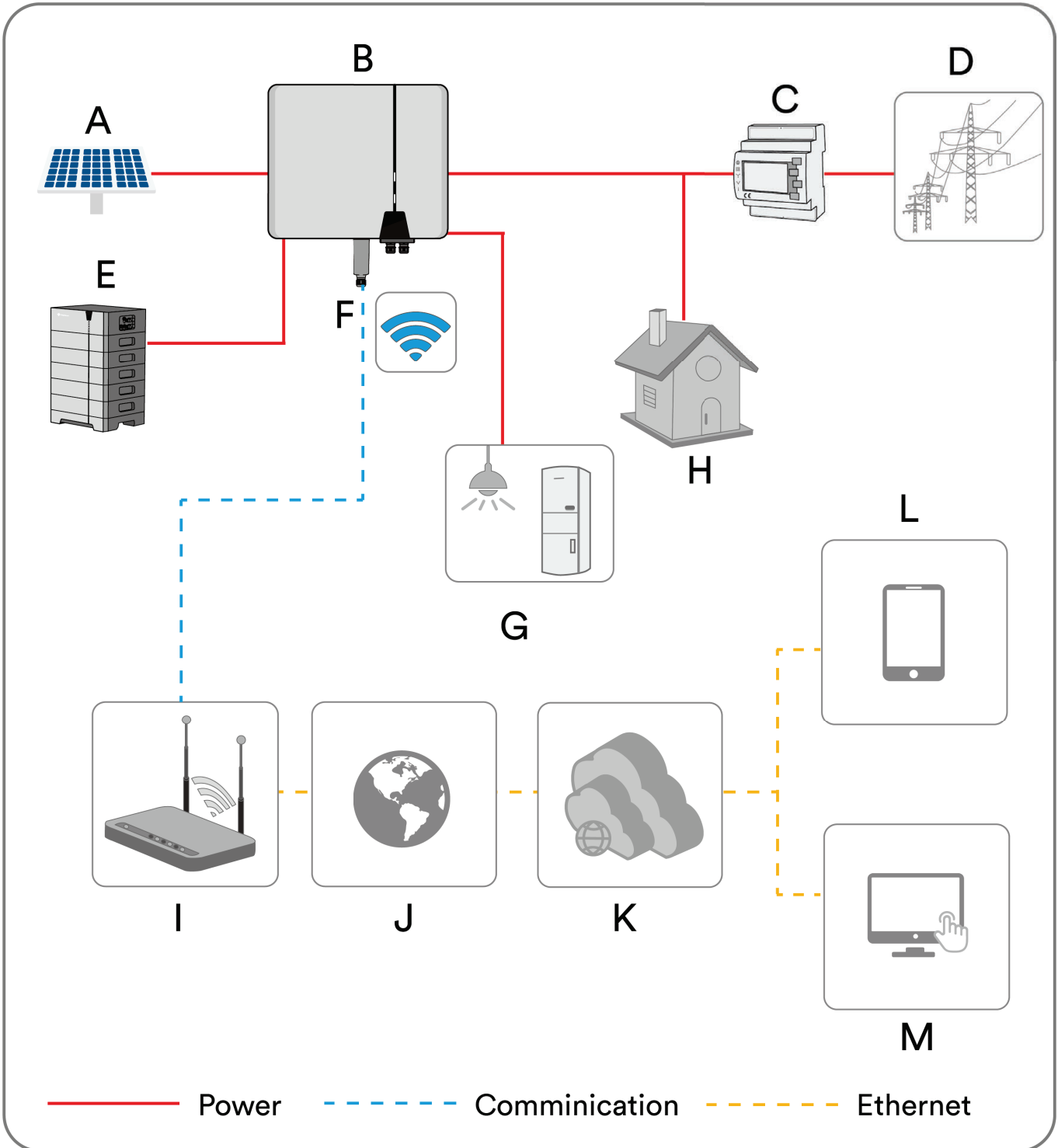



Object	Description	Remark
A	PV String	The product supports to connect the monocrystalline silicon, polycrystalline silicon, and thin-film without grounding.
B	Hybrid inverter	ASW H-T2 and ASW H-T3 series products have an EPS port. ASW H-T2-O and ASW H-T3-O series products doesn't have an EPS port.
C	Smart meter	The smart meter is the central device responsible for energy management. The smart meter also can be replaced by three current transformer which can communication with inverter directly.
D	Utility grid	The product can connect to TN and TT grounding system grid.
E	Battery system	The product must only be operated in connection with an intrinsically safe lithium-ion battery system approved by AISWEI.
F	Ai-Dongle	The Ai-Dongle supports Ethernet communication and WLAN communication. It is not recommended to use both communication methods at the same time.
G	EPS Load	The EPS load directly connected to the EPS port of the inverter. The EPS load can be power supplied by the inverter after the utility grid is failure.
H	Normally load	The normally load directly connected to utility grid. The normally load will be power off after the utility grid is failure.
I	Router	The product can connect to router through Wi-Fi signal or Ethernet cable.
J	Internet	The monitor information can transfer to Cloud Server through Internet.
K	Cloud server	The monitor information is stored at cloud server.
L	Smart phone	The APP can be installed on the smart phone and then review the monitor information.
M	Computer	The monitor information also can be review on the computer.

The system diagram of this product as follow:

For Australia and New Zealand, the neutral cable of On-grid side and EPS side must be connected together according to the wiring rules AS/NZS 3000. Otherwise the EPS function will not work.

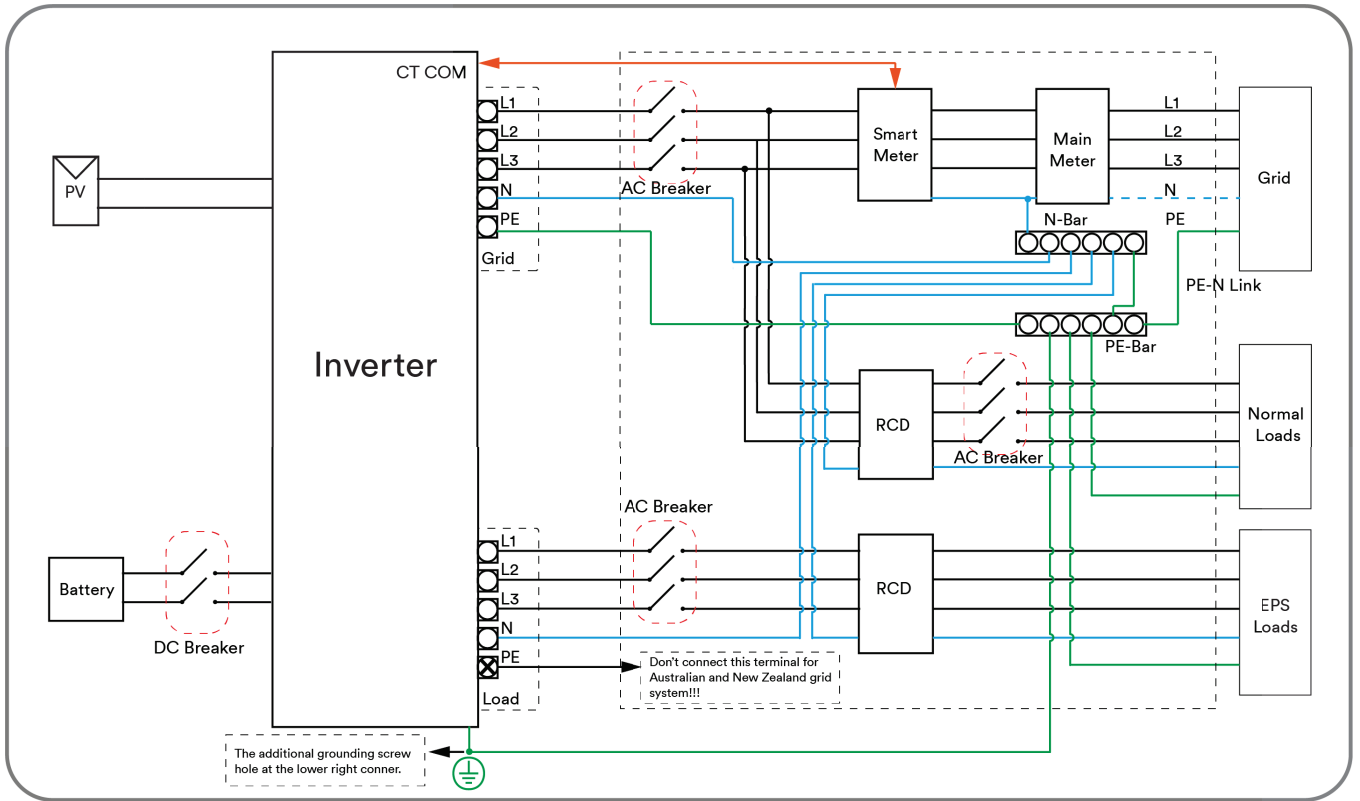

For other countries, the following diagram is an example for grid systems without special requirement on wiring connection.

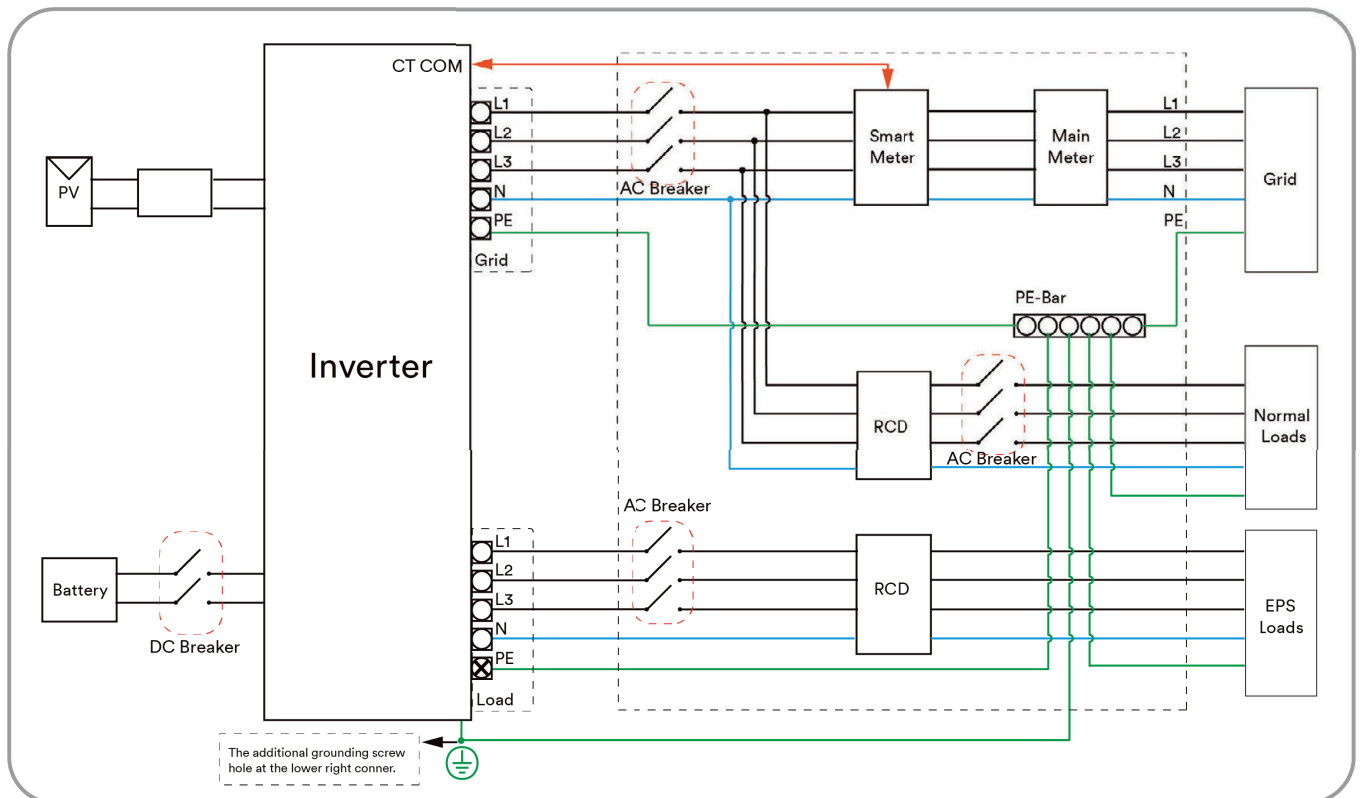

Current transformer connection and smart meter connection refer to 6.8.3 and 6.8.4.

## 4.7 Energy Management

The energy management mode depends on PV energy and user's preference. There are four energy management mode can be chosen.

### Self-Consumption mode

The photovoltaic energy is preferentially used by local load to improve the self-consumption rate and self-sufficiency rate.

The energy management during daytime:

Case 1: PV power generation is lower than the load power consumption, and the energy of the battery is not available.

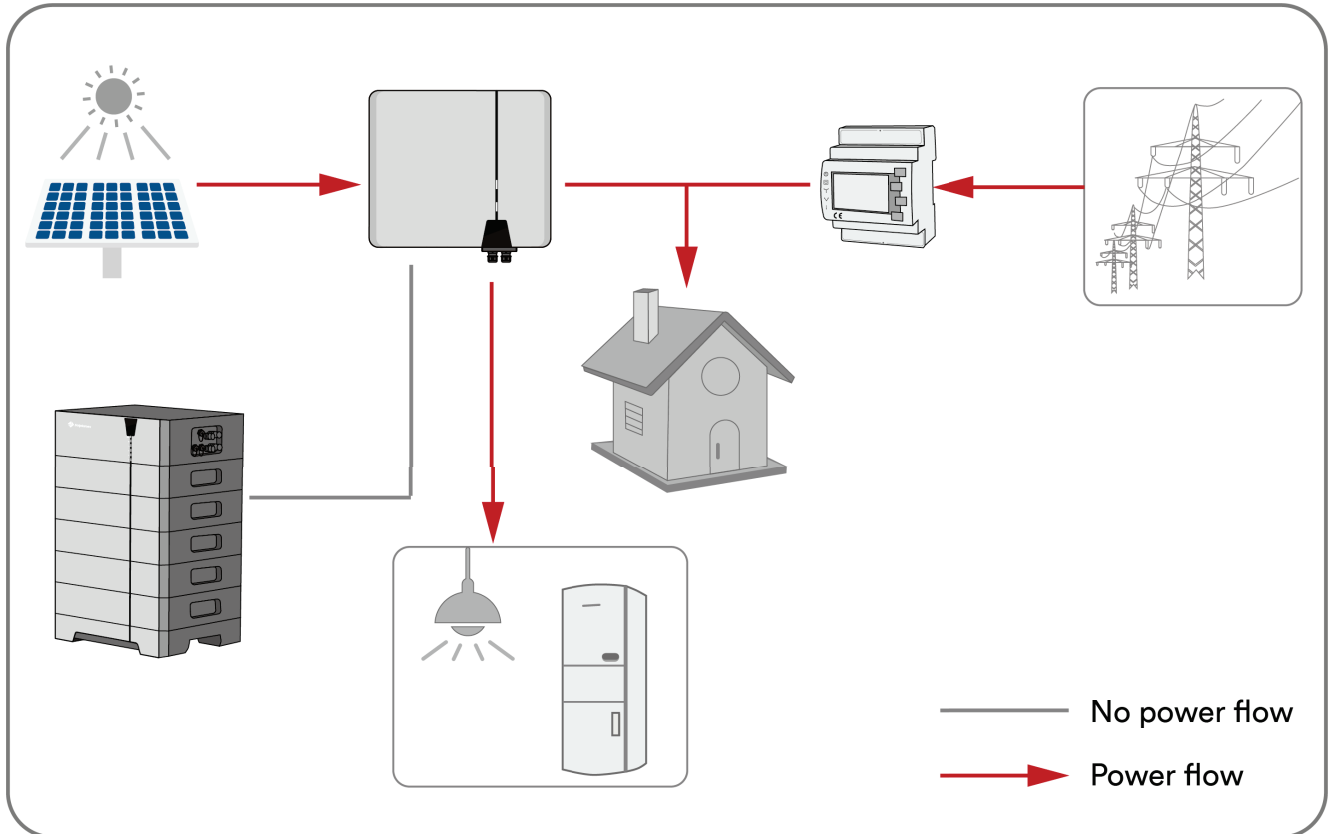

Case 2: PV power generation is lower than the load power consumption, and the energy of the battery is available.

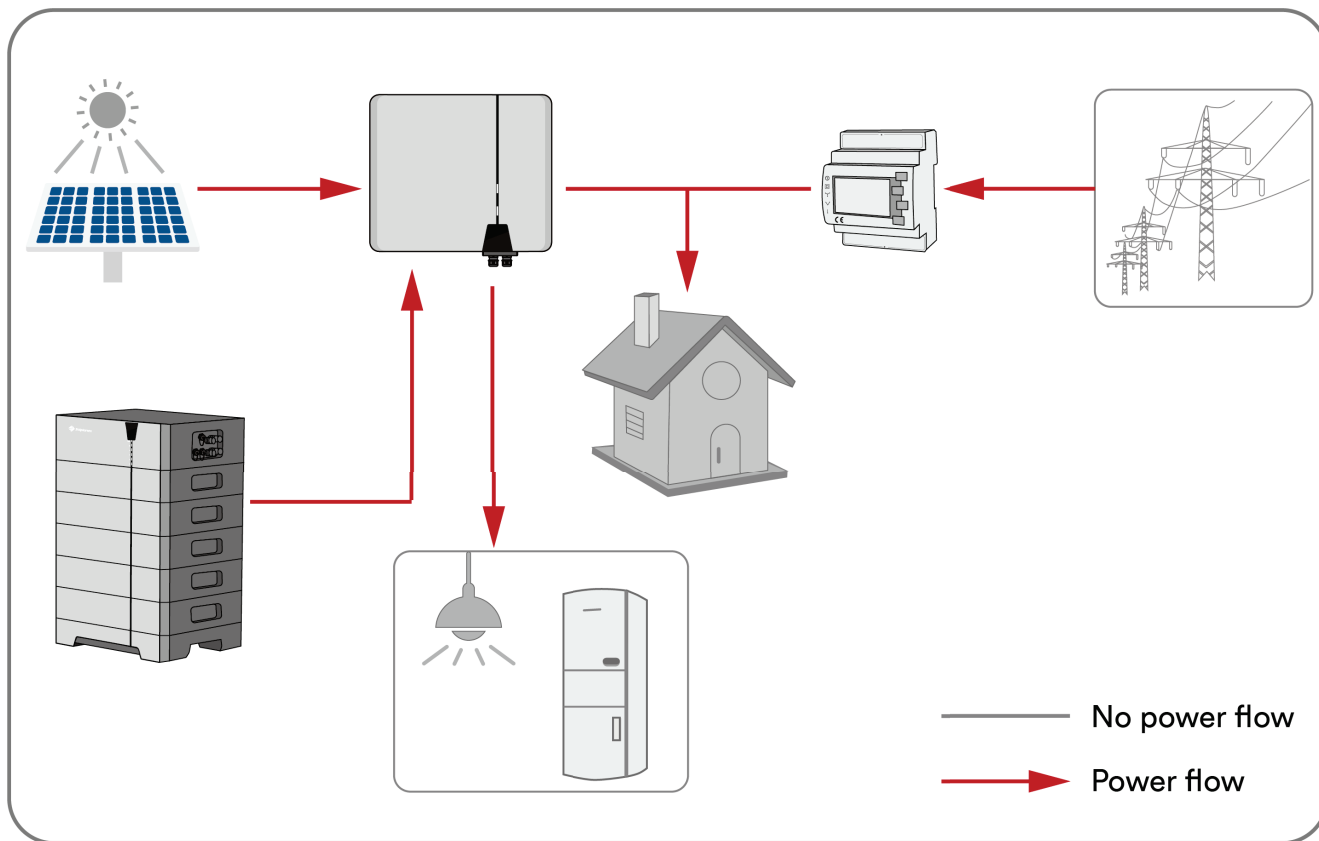

Case 3: PV power generation is larger than the load power consumption.

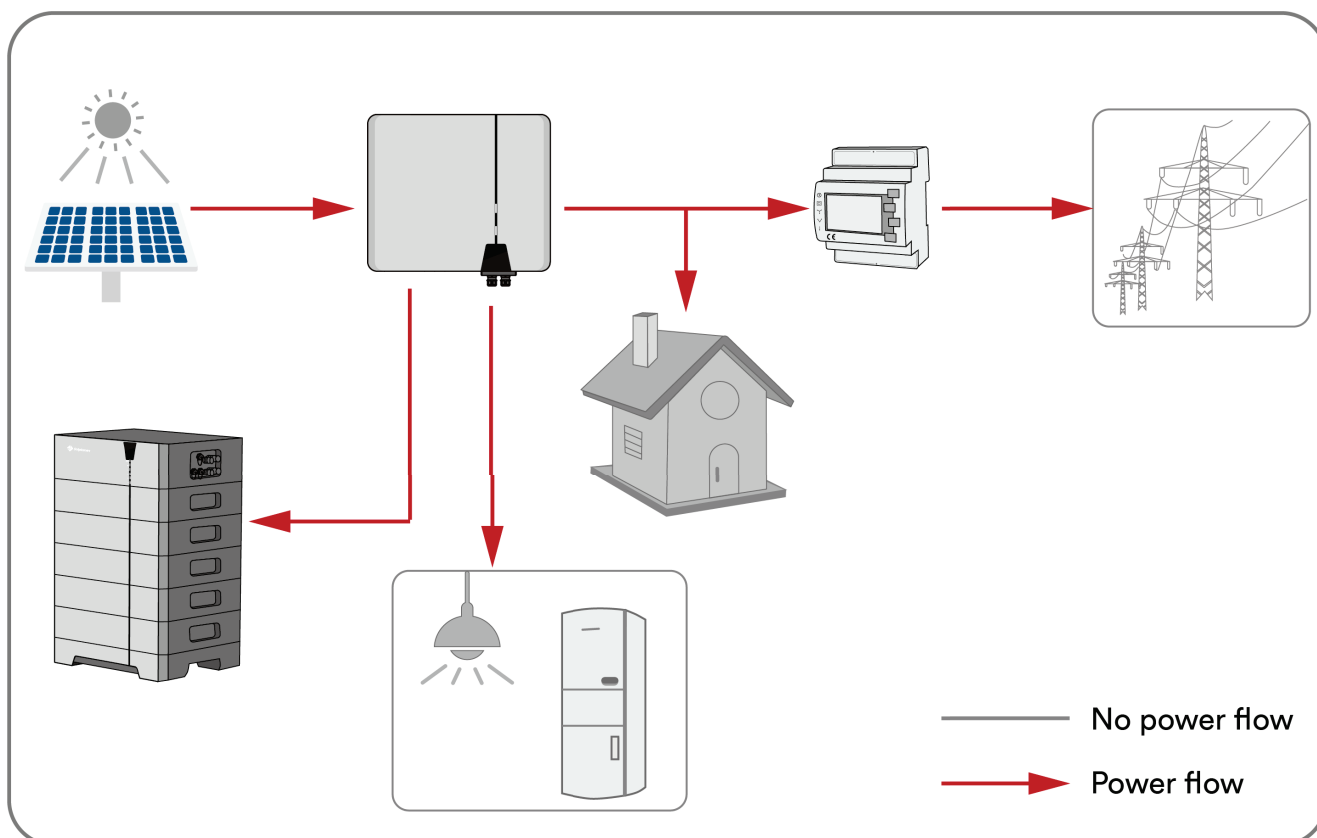

The energy management during night:

Case 1: The energy of the battery is available.

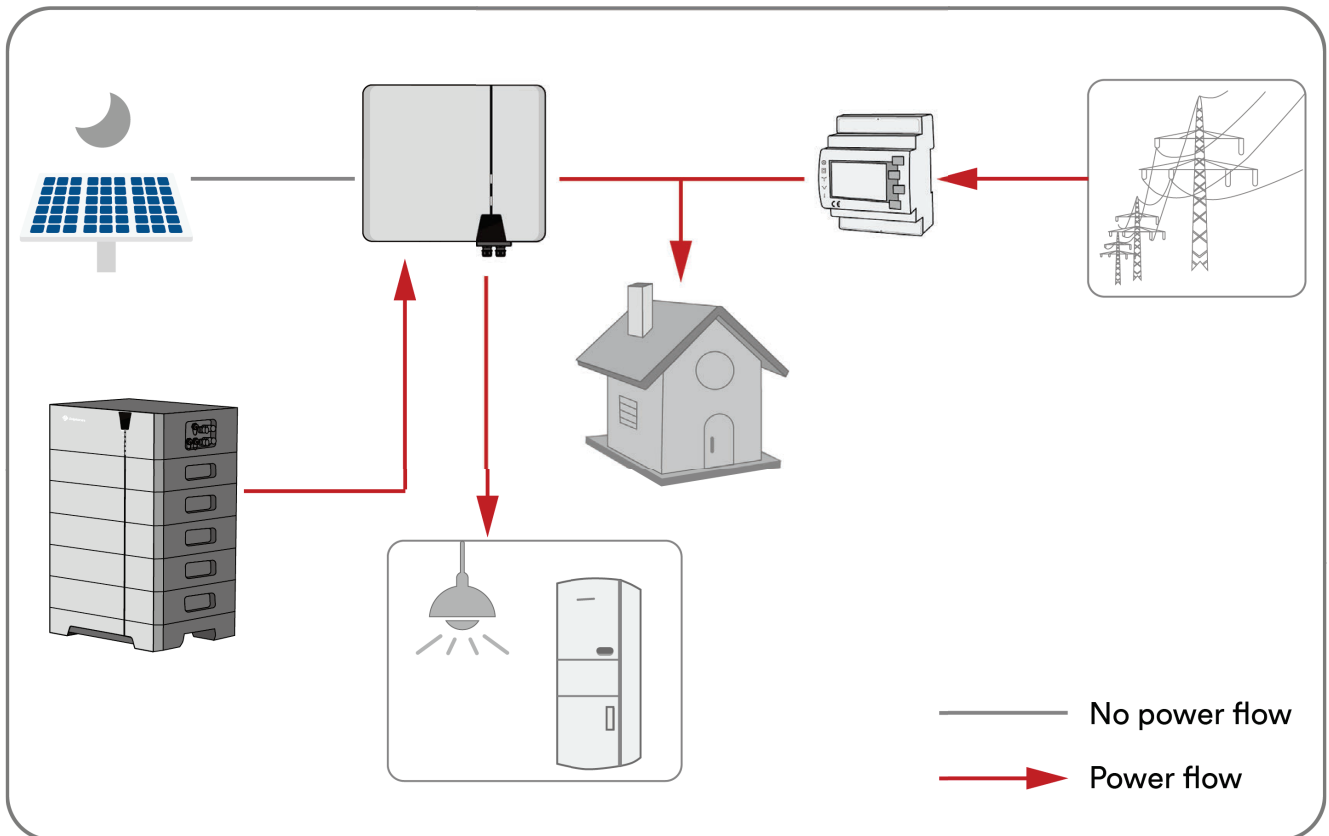

Case 2: The energy of the battery is not available.

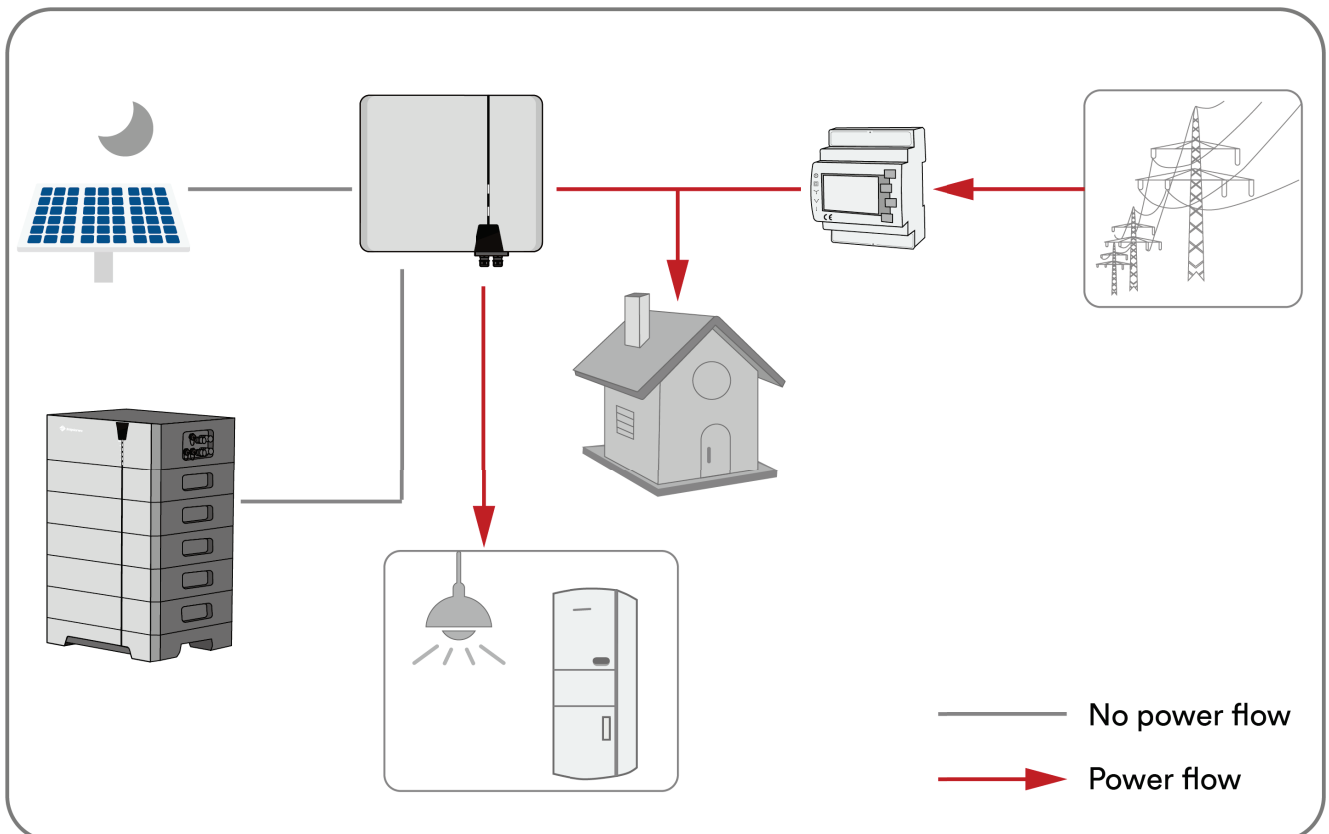

**Reserve mode**

The battery is a back-up energy storage device. The battery always charged by PV power if it is not full charged. The battery discharge only when the utility grid loss.

Case 1: The energy of the battery is not full charged.

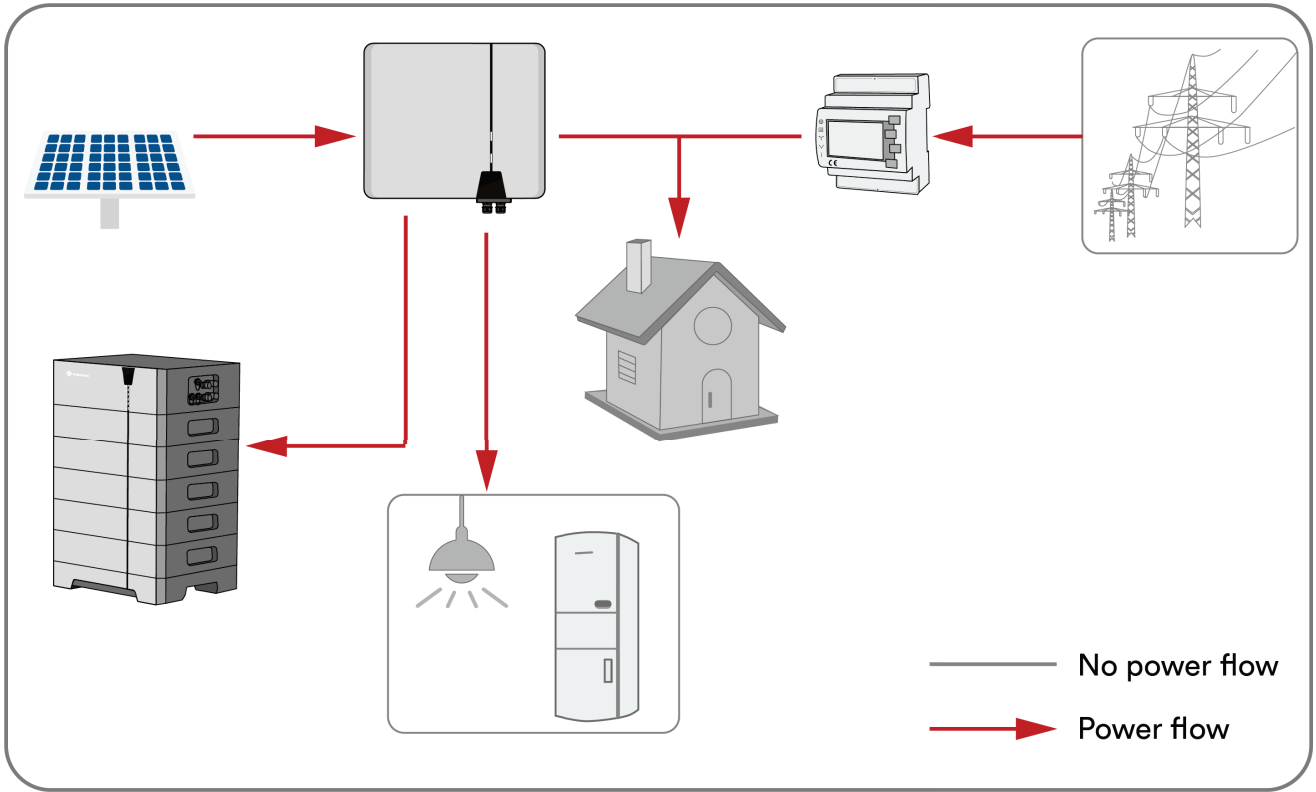

Case 2: The energy of the battery is full charged, even at night.

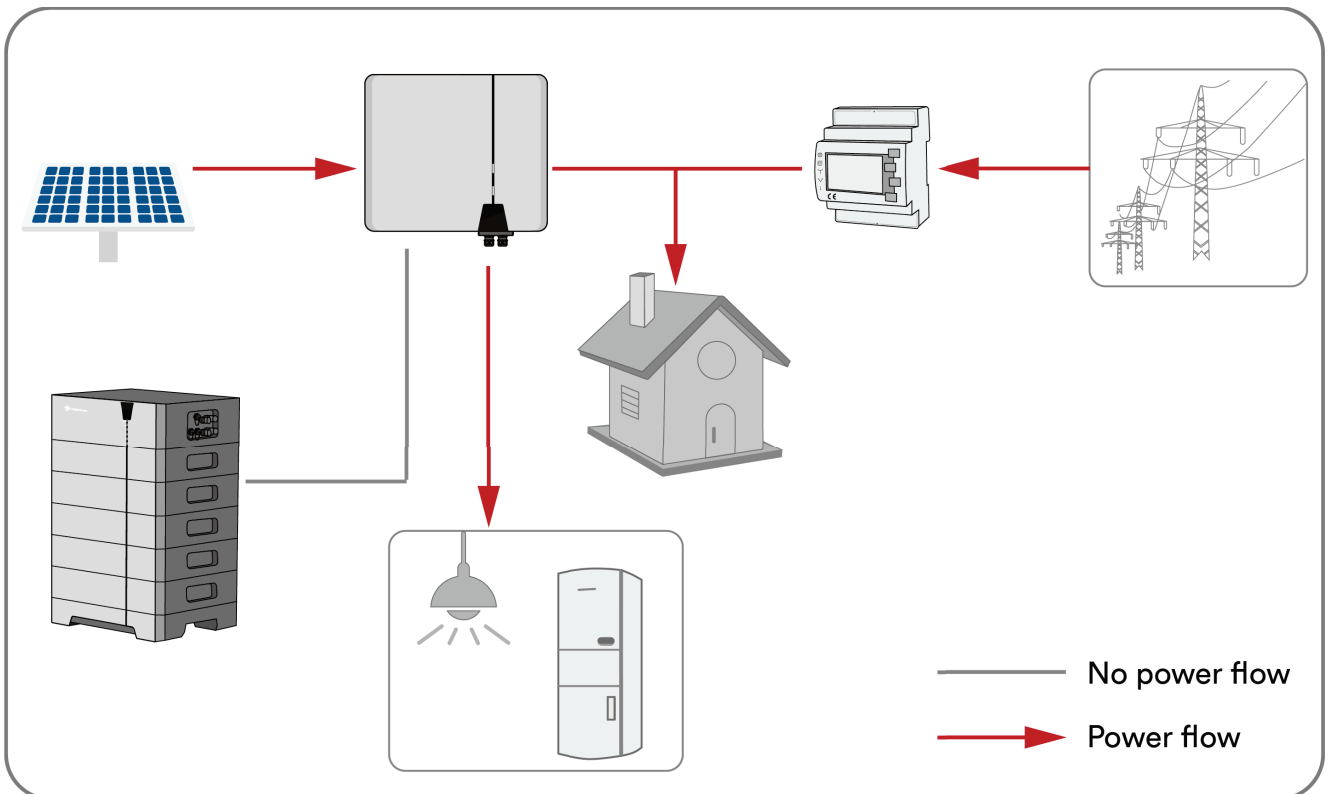

Case 3: The battery discharge when the utility grid loss.

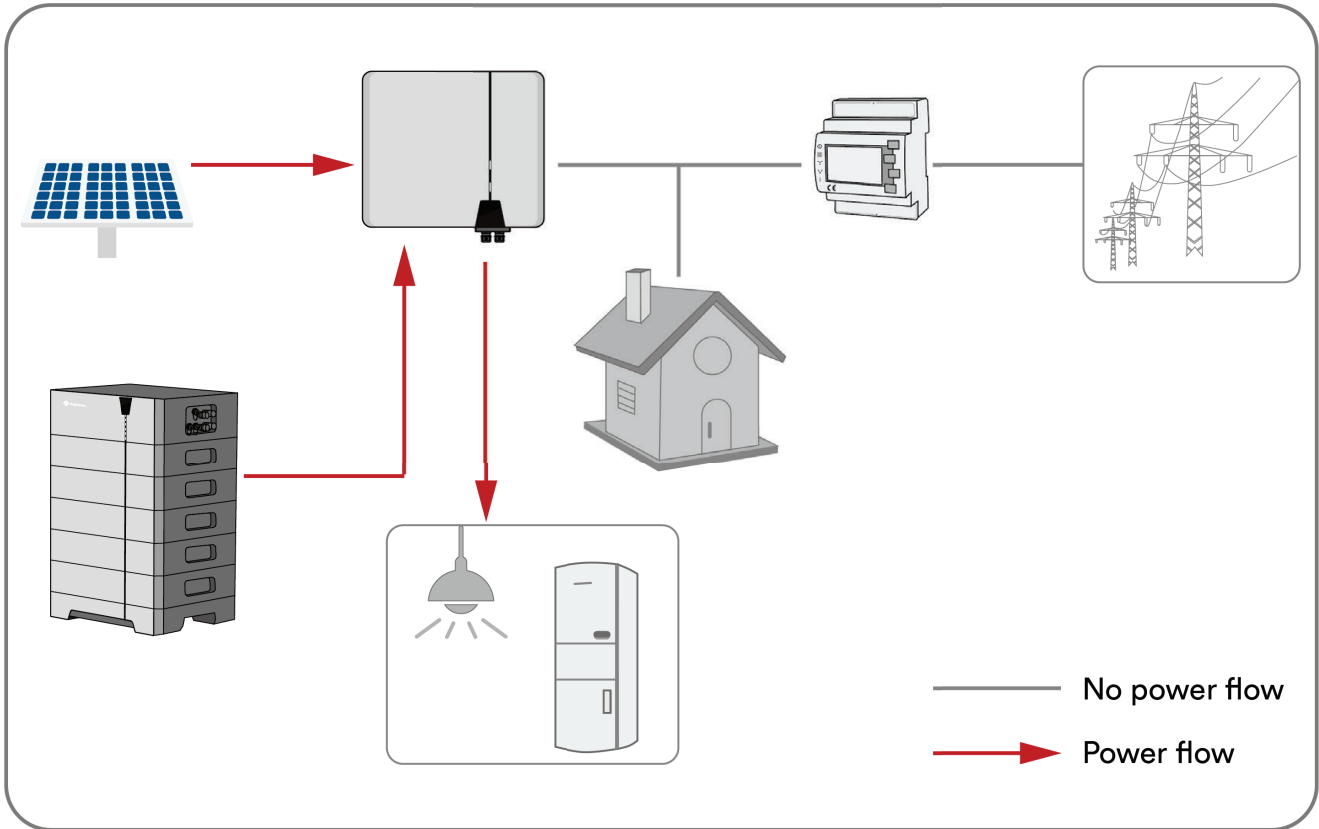

**Off-grid mode**

If the power grid is too weak and the inverter operating unstably, it is recommended that the customer switch to off grid mode to achieve stable power supply.

We will update this chapter with more details in an upcoming release.

**Custom mode**

In user-defined mode, customers can set their own charging and discharging time periods, and the charging and discharging power can be set by themselves in the APP.

We will update this chapter with more details in an upcoming release.

**Time of use mode**

If user choose load first, then inverter will operate in self-consumption mode when grid charge disable, and if grid charge enable the inverter will operate in back-up mode (battery SOC below the set point) or self-consumption mode(battery SOC above the set point)

If user choose battery first, the PV input power will charge battery firstly when grid charge disable, and if grid charge enable ,the inverter will operate in back-up mode(battery SOC below the set point) or self-consumption mode(battery SOC above the set point)。

We will update this chapter with more details in an upcoming release.

## 4.8 Parallel System

The hybrid inverter can operate as a parallel system. The system can even work when the utility grid is loss occasionally.

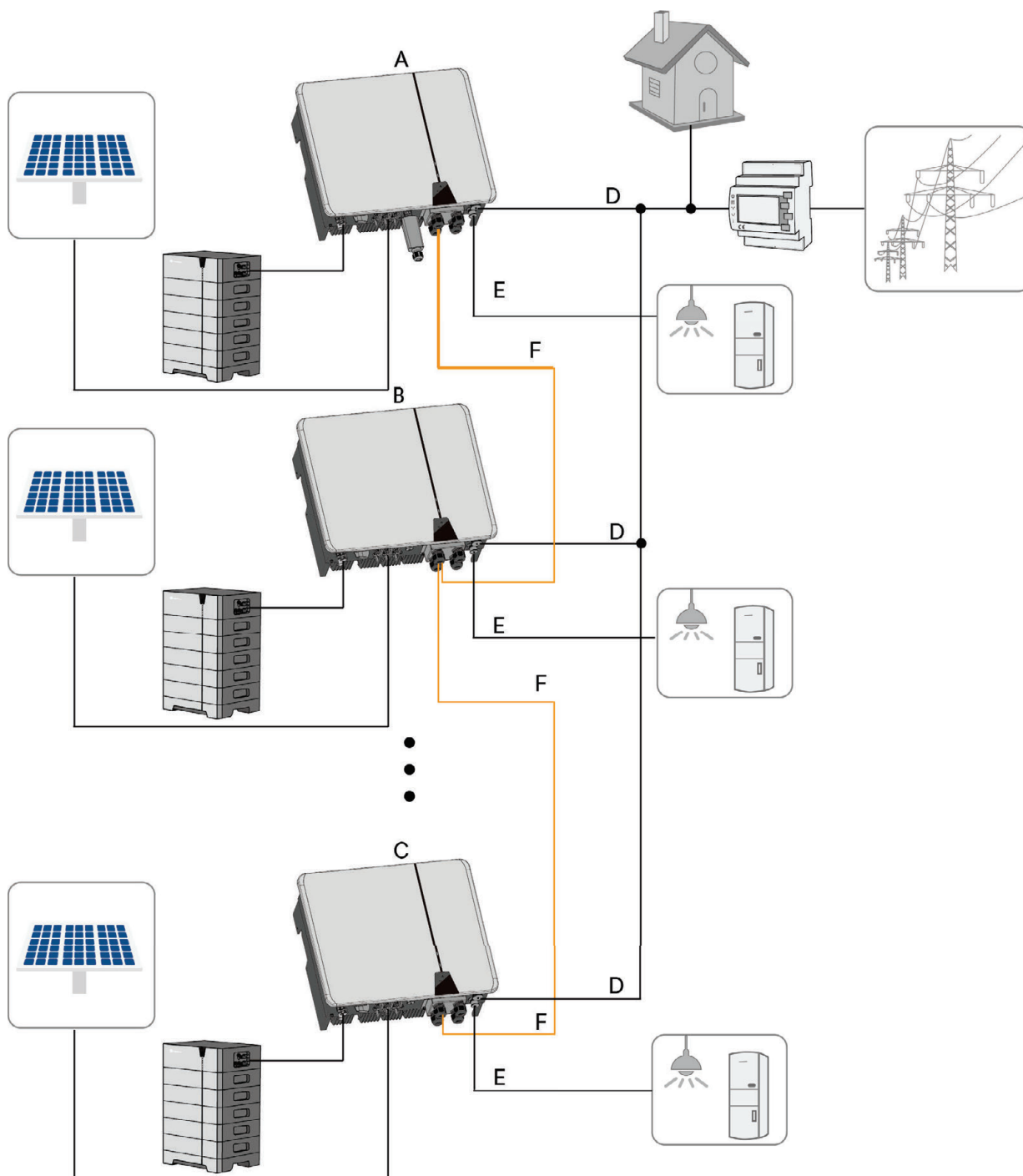

A	Master Inverter	B	Slaver Inverter 1	C	Slaver Inverter N
D	Grid port	E	EPS load port	F	Communication cable



Hybrid inverters with the same model can be connected in parallel in grid port. the EPS load should be independent of each inverter and the battery should be same model, show as follows.

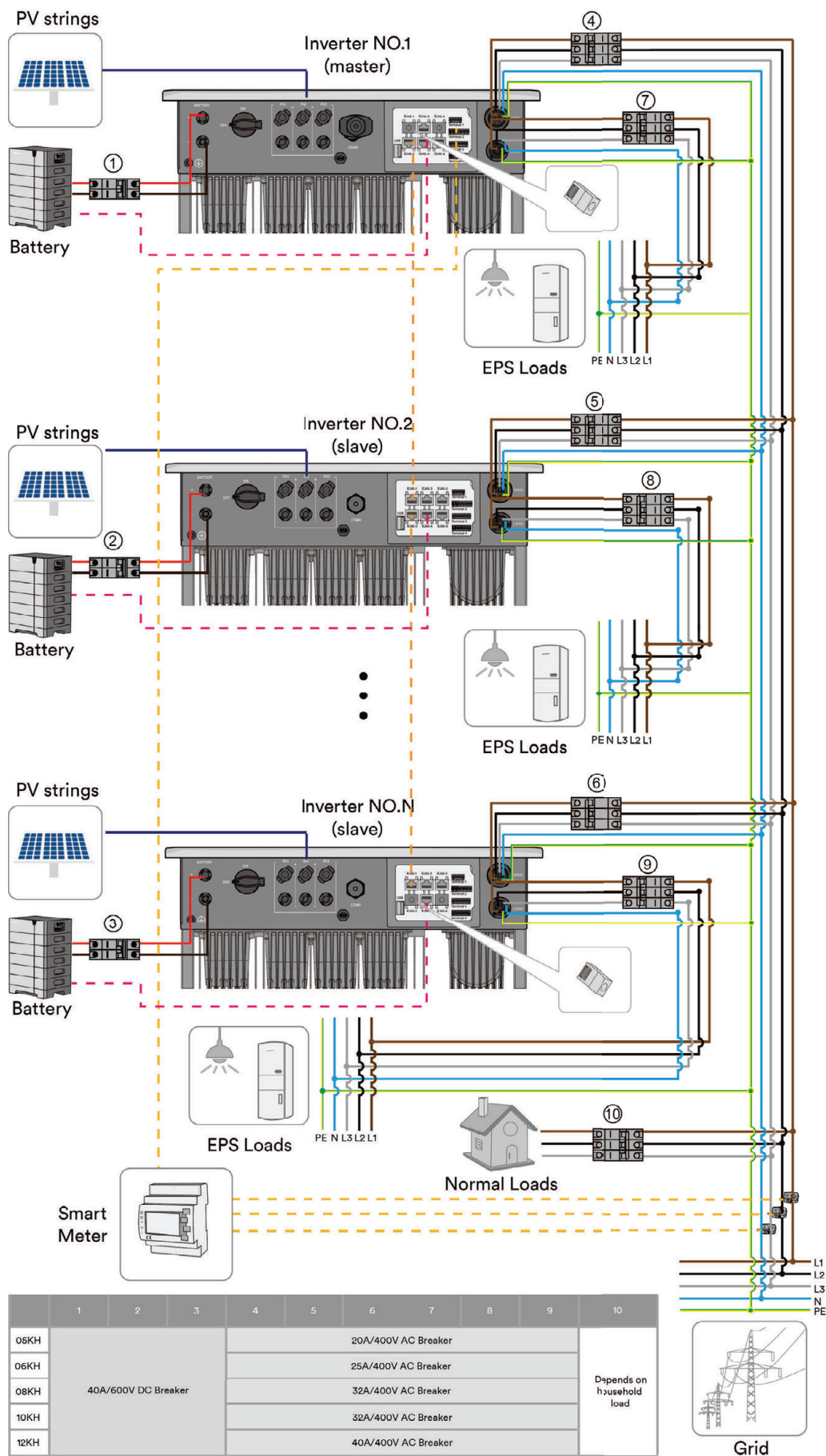

	1	2	3	4	5	6	7	8	9	10
05KH	40A/600V DC Breaker			20A/400V AC Breaker						Depends on household load
06KH				25A/400V AC Breaker						
08KH				32A/400V AC Breaker						
10KH				32A/400V AC Breaker						
12KH				40A/400V AC Breaker						

The smart meter type of parallel system can be SDM630 modbus V2 (MAX 100Arms) or SDM630MCT V2 with three ESCT-T24 CT (MAX 250Arms),customer can install the different type meter which can meet AC bus current requirement. CT should not used in parallel system.

## **NOTICE**

### **Damage to the inverter due to wiring error.**

Parallel system wiring must be performed as required, otherwise the product will not work properly or even be damaged.

- The phase sequence of the grid-side wiring of all parallel inverters must be completely consistent.
- The smart meter is connected to the AC bus, that is, when multiple units are running in parallel, the system share one smart meter, and the smart meter communication line is connected to the master inverter. The entire parallel system can only use one meter.
- The parallel system can only use one stick, which is connected to the master inverter.
- Use Ethernet cables for inverter communication to connect multiple inverters in series. The length of a single Ethernet cable should less than 20m. The two communication lines cannot be confused. After the wiring is completed, the empty communication ports of the first and last inverter are inserted into a RJ45 port terminal resistance in the accessory bag.
- Select the battery type in the APP of master inverter. The process steps are the same as the single inverter settings. Please refer to Chapter 8.4.

## **NOTICE**

### **Adding inverters or deleting inverters in the parallel system requires re-scanning the inverter (the network cable and 120ohm matching resistor are connected according to the inverter).**

- Replace the master and slave inverters on the premise that both the inverters in the parallel system are good: cut off all inverter power, move the stick and meter terminal to new master inverter, and connect the Ethernet cable and 120ohm matching resistor along with the new master inverter, and then power on, wait until the green light on the stick is always on, click to scan the inverter. After the new system is scanned out, the replacement is completed.
- When the master inverter of the parallel system is broken and all inverters are powered off, replace the master inverter: power off all the inverter, move the stick and meter to new master inverter, the Ethernet cable and 120ohm matching resistor are also connected with the replacement of the master inverter, and then all power on, wait for the green light on the stick to turn on, click to scan the inverter. After the new system is scanned out,. At this time, the replacement is completed.

## 5 Mounting

### 5.1 Requirements for mounting

#### **DANGER**

Danger to life due to fire or explosion!

Despite careful construction, electrical devices can cause fires. This can result in death or serious injury.

Do not mount the product in areas containing highly flammable materials or gases.

Do not mount the inverter in areas where there is a risk of explosion.

- The ambient temperature is recommended below 40°C to ensure optimal operation.
- A solid support surface must be available (e.g., concrete or masonry). Ensure that the installation surface is solid enough to bear four times the weight. When mounted on drywall or similar materials, the product emits audible vibrations during operation which could be perceived as annoying.
- The mounting location must be inaccessible to children.
- The mounting location should be freely and safely accessible at all times without the need for any auxiliary equipment (such as scaffolding or lifting platforms). Non-fulfillment of these criteria may restrict servicing.
- The mounting location must not be exposed to direct solar irradiation. If the product is exposed to direct solar irradiation, the exterior plastic parts might age prematurely and overheating might occur. When becoming too hot, the product reduces its power output to avoid overheating.

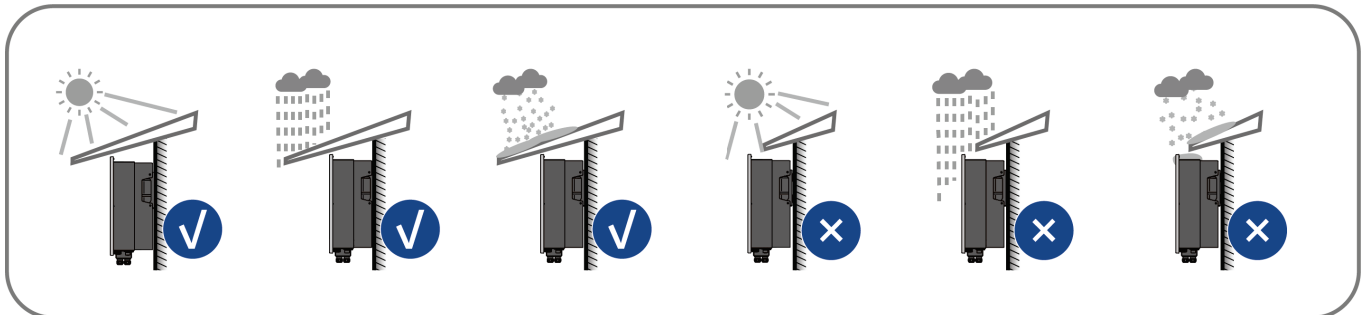

- Never install the inverter horizontally, or with a forward / backward tilt or even upside down. The horizontal installation can result in damage to the inverter.

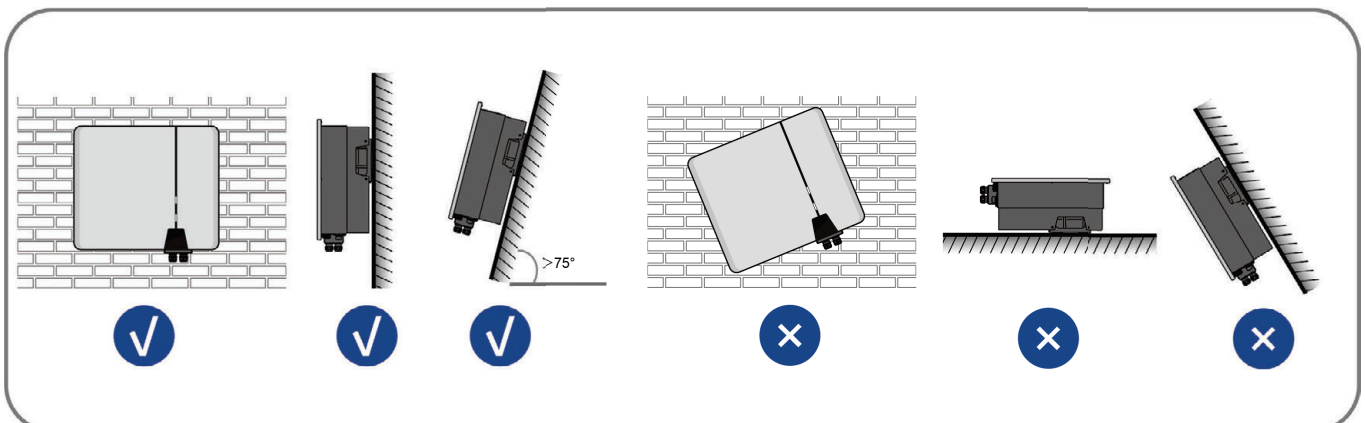

Maintain the recommended clearances to wall as well as to other inverters or objects.

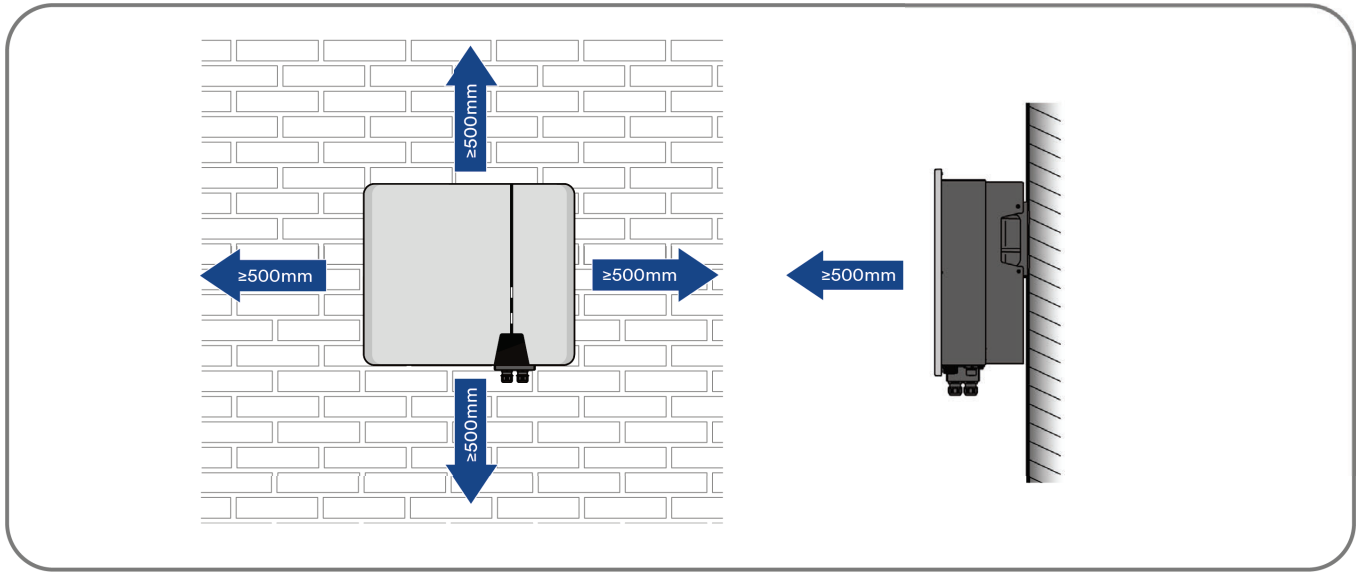

- In case of multiple inverters, reserve specific clearance between the inverters.

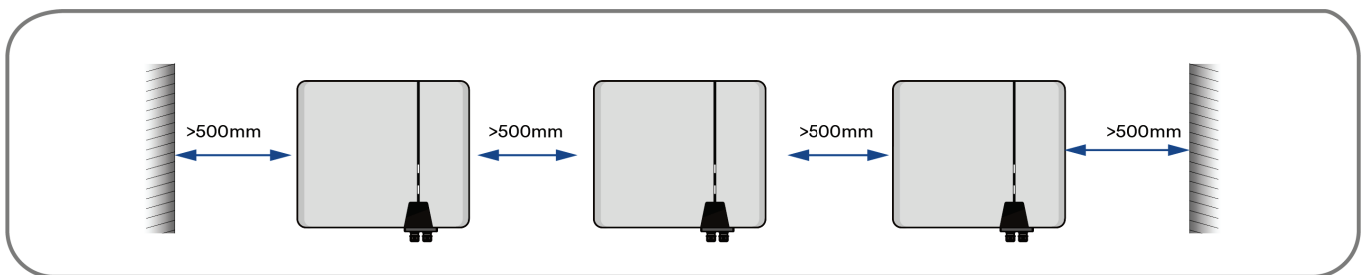

The product should be mounted such that the LED signals can be read off without difficulty.

The DC load-break switch of the product must always be freely accessible.

## 5.2 Taking out and moving the product

Open the inverter packaging box, take the inverter out of the packaging box, and place the inverter at the designated installation location.

### CAUTION

Risk of injury due to the weight of the product!

The net weight of this product is 26kg. If the inverter is lifted incorrectly during the installation, it may fall down and cause injury or equipment damage.

Transport and lift the product carefully. Take the weight of the product into account.

Wear suitable personal protective equipment for all work on the product.

## 5.3 Mounting

**Step 1:** Align the mounting-bracket horizontally on the wall with the arrow upwards. Mark the position of the drill hole. Set the wall mounting bracket aside and drill the marked holes with the diameter of 10mm. The depth of the holes should be about 70 mm. Keep the hammer drill bit perpendicular to the wall to avoid drilling inclined.

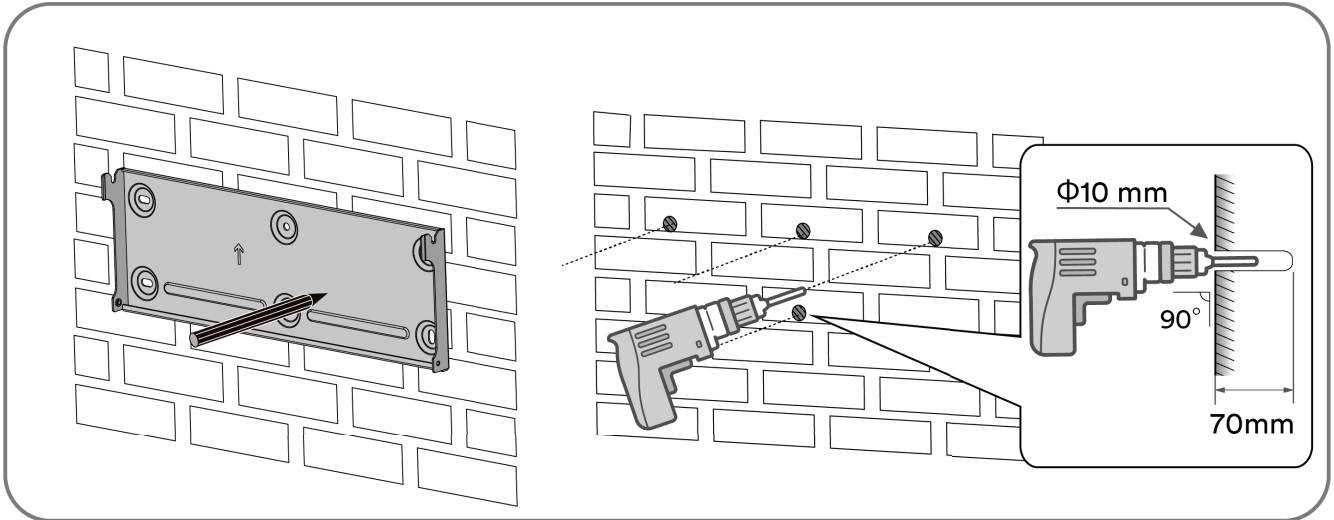

**Step 2:** Hammer the plastic expansion pipe slowly into the drilled hole.

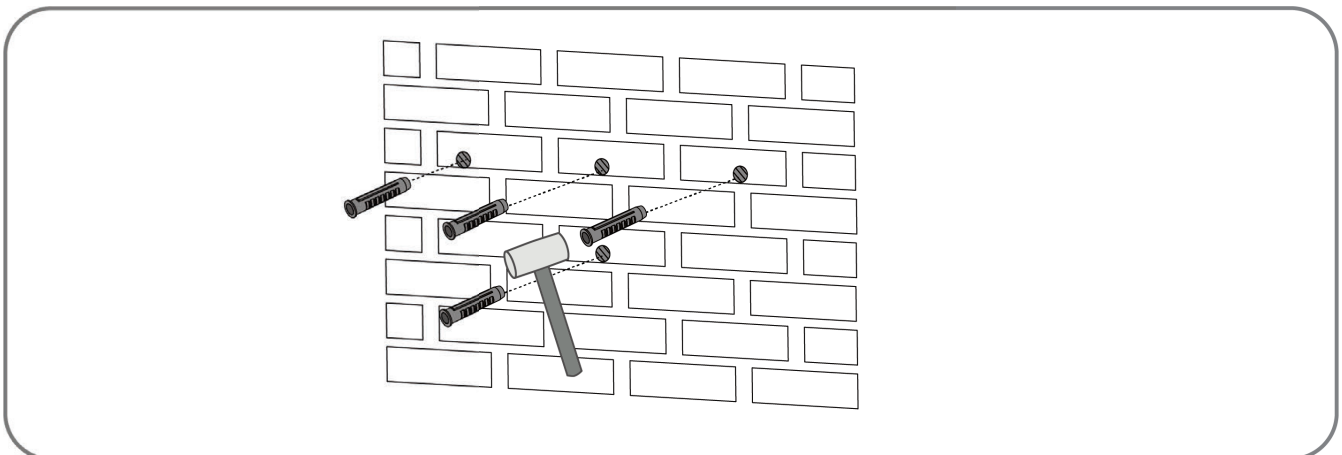

**Step 3:** Align the mounting-bracket with the hole position and use the tapping nail to fix the hanging plate.

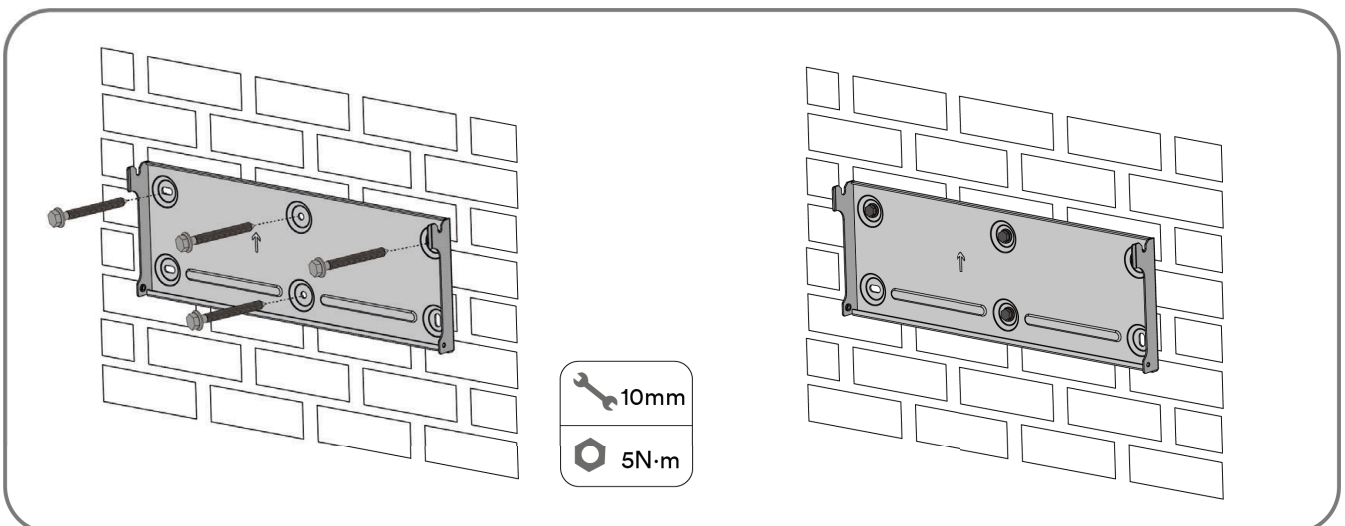

**Step 4:** Hang the inverter to the mounting-bracket and ensure that the mounting ears perfectly engage with the mounting-bracket.

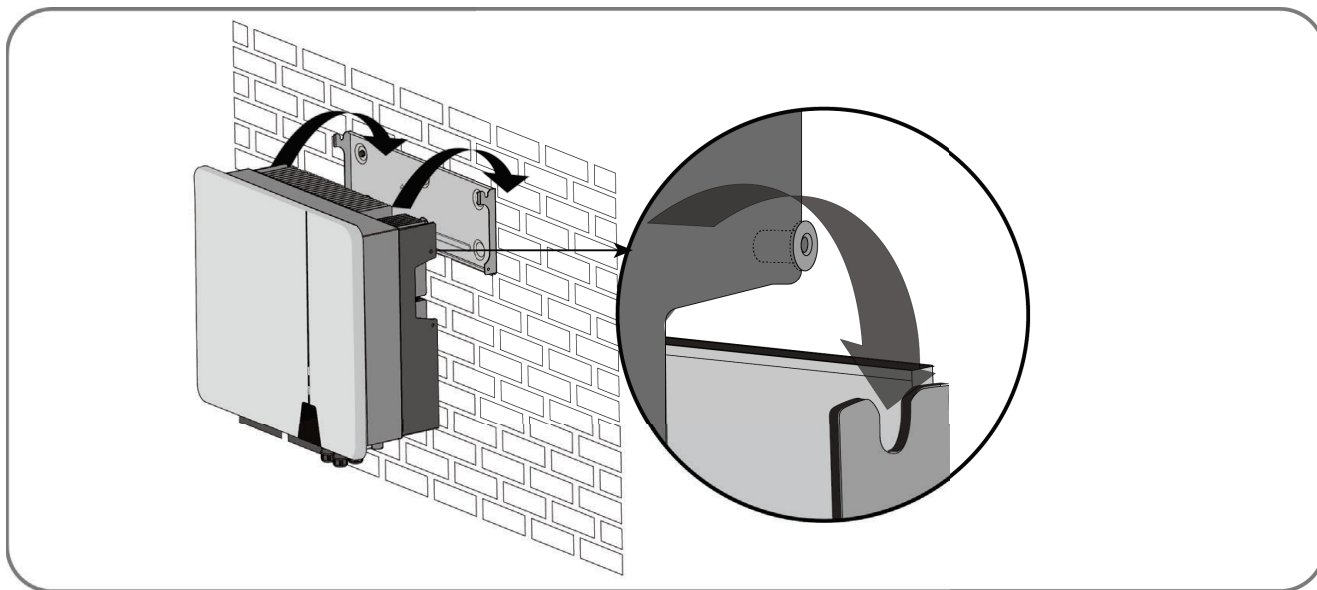

**Step 5:** Fix the inverter with screws.

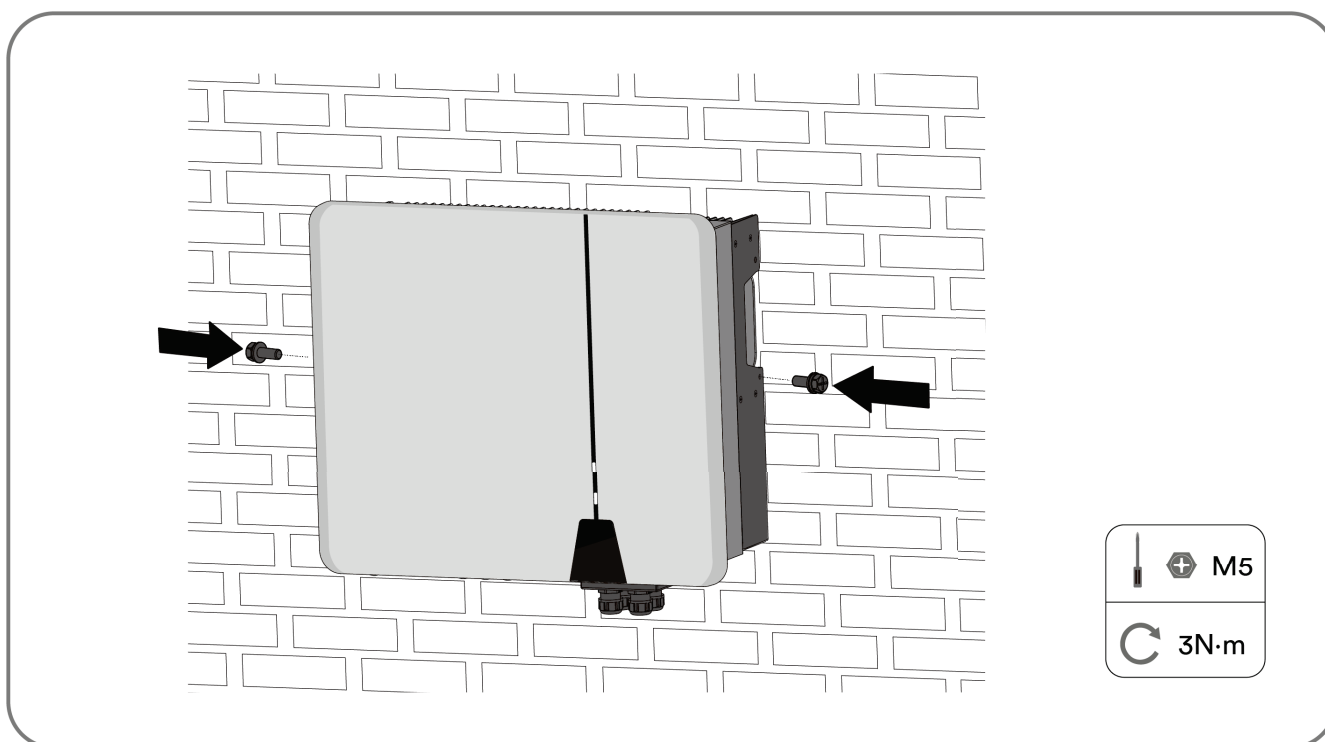

**Complete the installation.**

## 6 Electrical connection

### 6.1 Connection port description

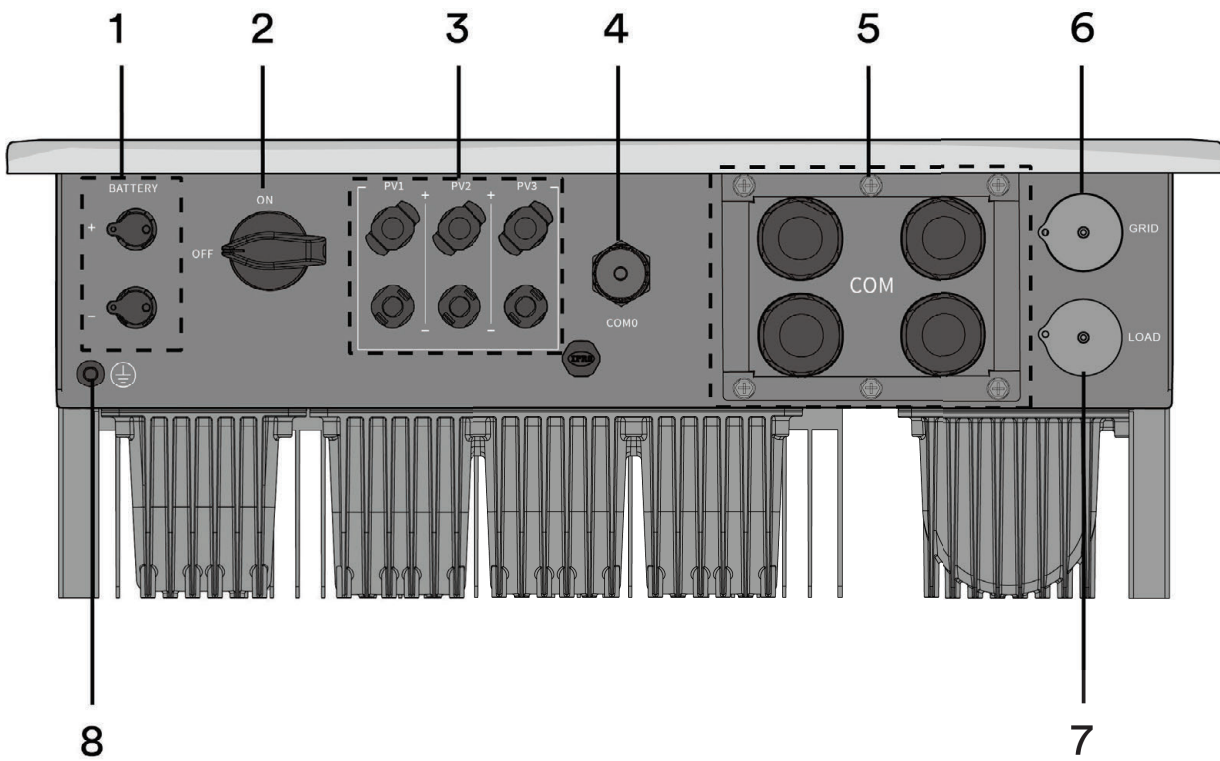
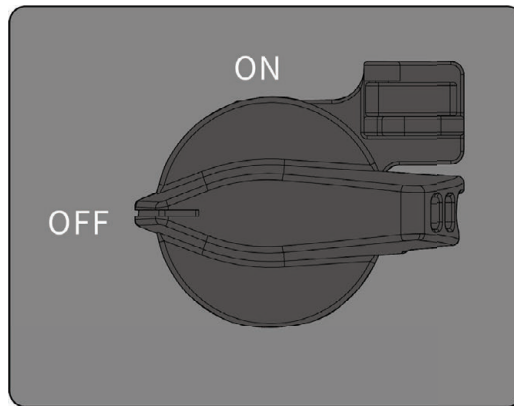

Figure shown here is for reference only. The actual product received may differ!

Object	Description
1	Battery Port
2	DC-switch
3	PV Input
4	Ai-Dongle
5	Communication ports
6	AC connector
7	EPS Load connector
8	Additional grounding screw



For the Australian market, the DC switch is shown below:



## 6.2 Connecting additional grounding

The inverter is equipped with a grounding conductor monitoring device. This grounding conductor monitoring device detects when there is no grounding conductor connected and disconnects the inverter from the utility grid if this is the case. Hence the product does not require an additional grounding or equipotential bonding when operating.

If the grounding conductor monitoring function is deactivated or the additional grounding is required by locally standard, you can connect additional grounding to the inverter.

### Requirements for the secondary protection ground cable:

Item	Description	Note
1	Screw	Specifications M5, complimentary
2	OT/DT terminal	Specifications M5, complimentary
3	Yellow and green ground cable	Same as the PE wire in the AC cable.

### Procedure:

**Step 1:** Strip the grounding cable insulation. Insert the stripped part of the grounding cable into the ring terminal lug and crimp using a crimping tool.

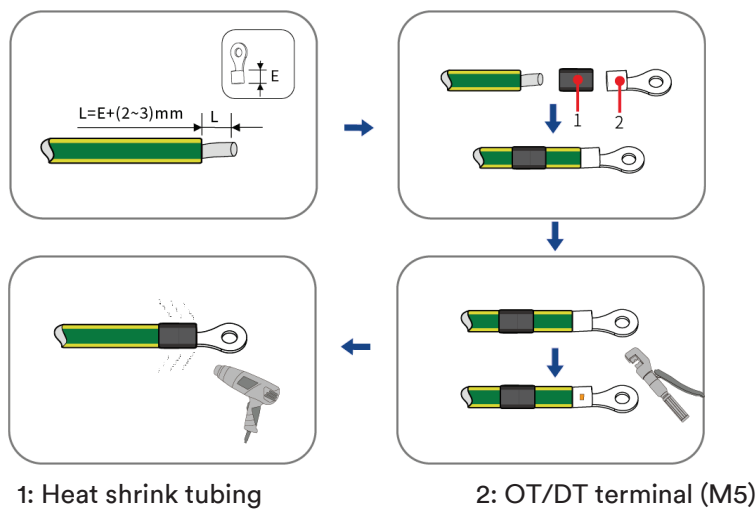

**Step 2:** Remove the screw on the ground terminal, insert the screw through the OT/DT terminal, and lock the terminal using a wrench.



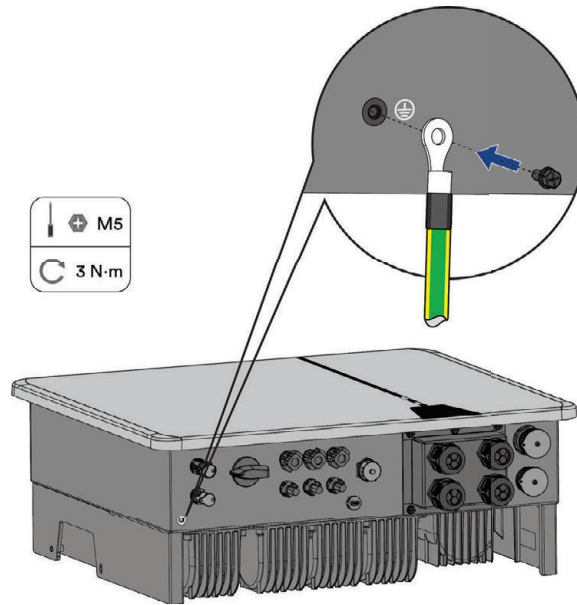

**Step 3:** Apply paint to the grounding terminal to ensure corrosion resistance.

Complete the installation.

## 6.3 Grid cable connection

### 6.3.1 Requirements for the Grid connection

#### Cable Requirements

The cable must be dimensioned in accordance with the local and national directives for the dimensioning of cables. The requirements for the minimum wire size derive from these directives. Examples of factors influencing cable dimensioning are: nominal AC current, type of cable, routing method, cable bundling, ambient temperature and maximum desired line losses.

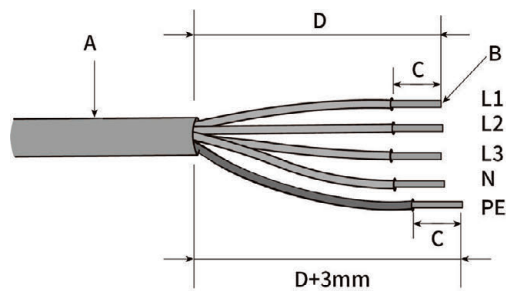

Item	Description	Value
A	External diameter	12.5...17.5 mm
B	Copper cable conductor cross-section	4~6 mm <sup>2</sup>
C	Insulation stripping length	10 mm
D	Sheath stripping length	40 mm

#### Residual current protection

The product is equipped with an integrated universal current-sensitive residual current monitoring unit inside. Hence the product does not require an external residual-current device when operating.



If local regulations require the use of a residual-current device, please install a type A residual-current protection device with a protection limit of not less than 300mA.

### Overvoltage category

The inverter can be used in grids of overvoltage category III or lower in accordance with IEC 60664-1. That means that the product can be permanently connected to the grid-connection point of a building. In case of installations with long outdoor cable route, additional measures to reduce overvoltage category IV to overvoltage category III are required.

### AC circuit breaker

In PV systems with multiple inverters, protect each inverter with a separate circuit breaker. This will prevent residual voltage being present at the corresponding cable after disconnection.

No consumer load should be applied between AC circuit breaker and the inverter.

The selection of the AC circuit breaker rating depends on the wiring design (wire cross-section area), cable type, wiring method, ambient temperature, inverter current rating, etc. Derating of the AC circuit breaker rating may be necessary due to self-heating or if exposed to heat.

The maximum output current and the maximum output overcurrent protection of the inverters can be found in section 10 “Technical data”.

### Grounding conductor monitoring

The inverter is equipped with a grounding conductor monitoring device. This grounding conductor monitoring device detects when there is no grounding conductor connected and disconnects the inverter from the utility grid if this is the case. Depending on the installation site and grid configuration, it may be advisable to deactivate the grounding conductor monitoring. This is necessary, for example, in an IT system if there is no neutral conductor present and you intend to install the inverter between two line conductors. If you are uncertain about this, contact your grid operator or AISWEI.



Safety in accordance with IEC 62109 when the grounding conductor monitoring is deactivated.

In order to guarantee safety in accordance with IEC 62109 when the grounding conductor monitoring is deactivated, carry out the following measure.

Connect an additional grounding that has at least the same cross-section as the connected grounding conductor to the AC cable. This prevents touch current in the event of the grounding conductor on the AC cable failing.

## 6.3.2 Assembling the grid connectors

**Step 1:** Switch off the miniature circuit-breaker or the switch of every energy sources and secure it against being inadvertently switched back on.

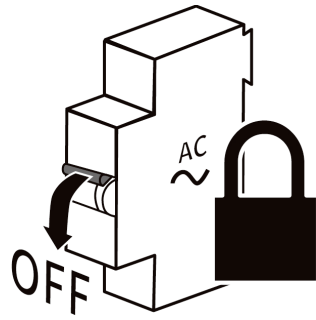

**Step 2:** Split grid connector.

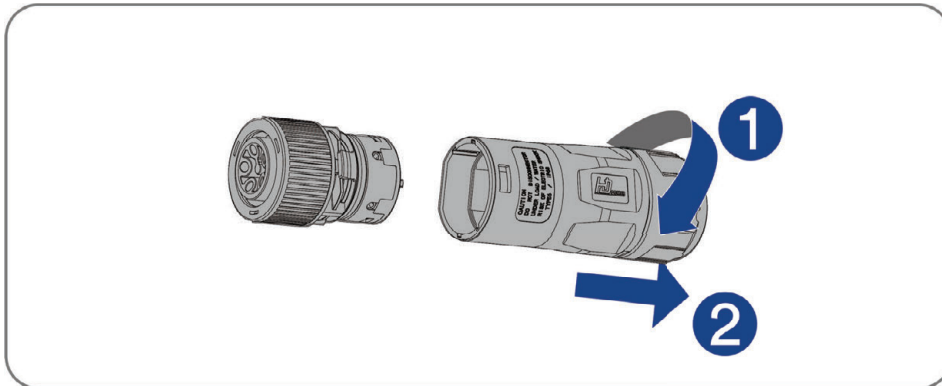

**Step 3:** Crimp the terminals with crimping pliers.

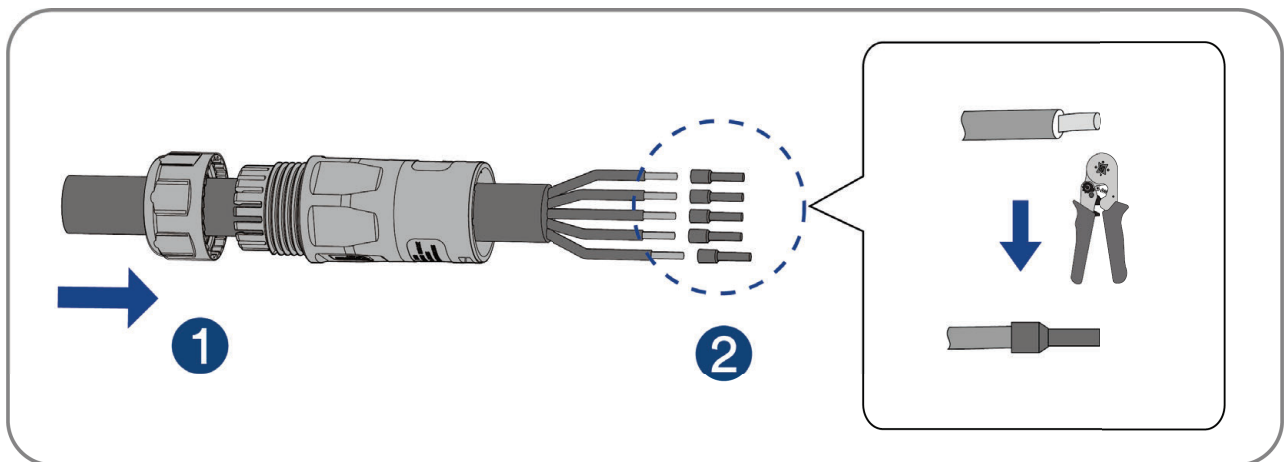

Crimping tool selection and crimping requirements are shown in the following figure:

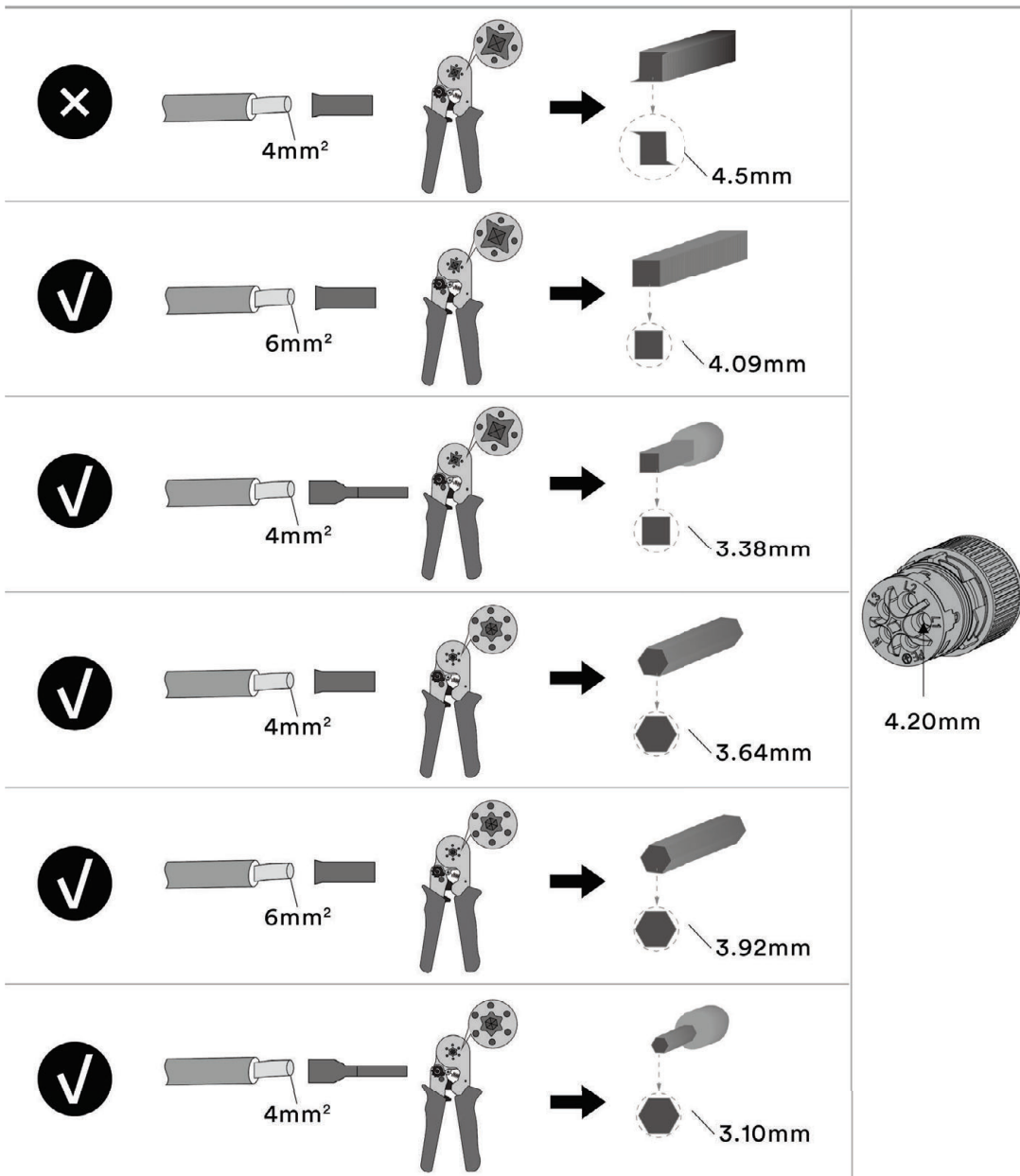

**Step 4:** Set the parts on the cable, insert the terminal holes in sequence. Crimp the wire with an inner hexagon screwdriver and screw the torque  $1.2 \pm 0.1 \text{ N}\cdot\text{m}$ .

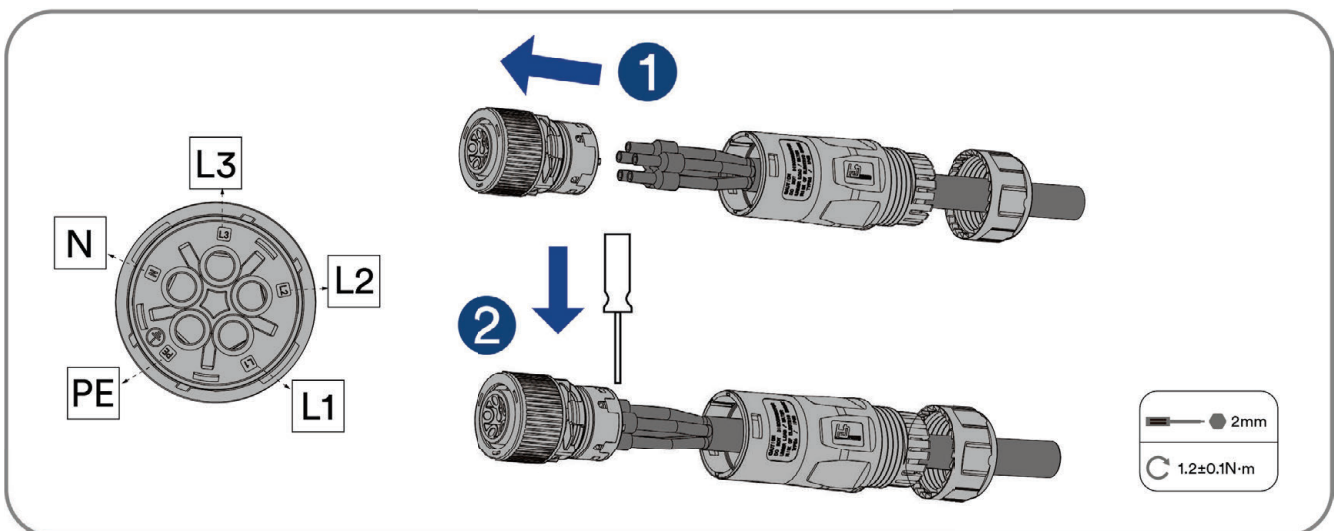

**Step 5:** Insert the main body into the rubber core and hear the “click” sound.

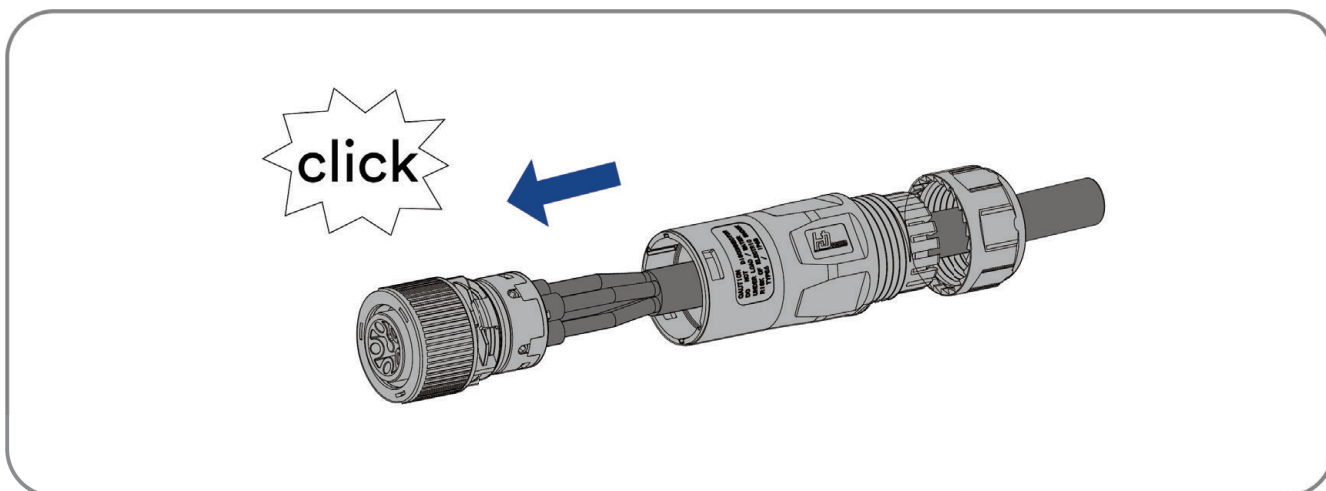

**Step 6:** Tighten the nut with an open-ended wrench (torque  $2.5 \pm 0.5$  N·m).

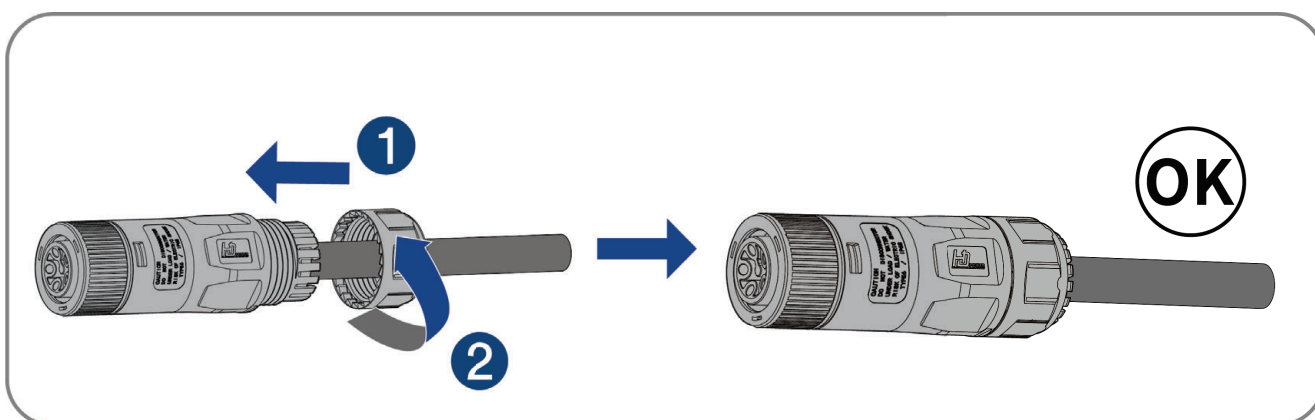

The following figure shows the sequence of the AC connector cable harness.

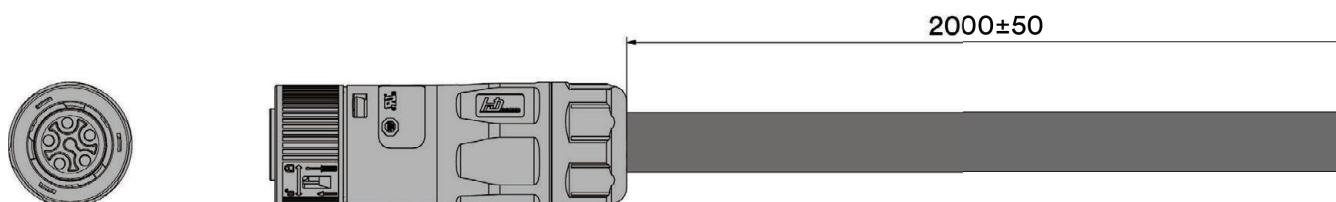

Object	icon	Connector number	Line color
1		L1	brown
2		L2	black
3		L3	grey
4		L4	blue
5		PE	Yellow-green

### 6.3.3 Connecting the grid connectors

**Step 1:** Remove the dust cover.

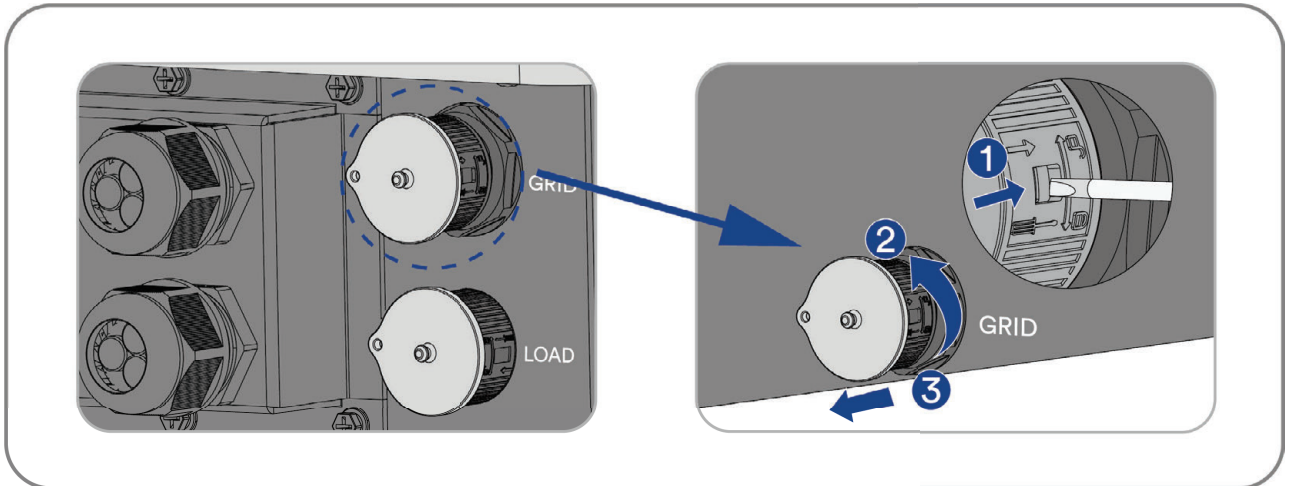

**Step 2:** The installation arrow indicates insertion the female connector, and hear the “click” sound.

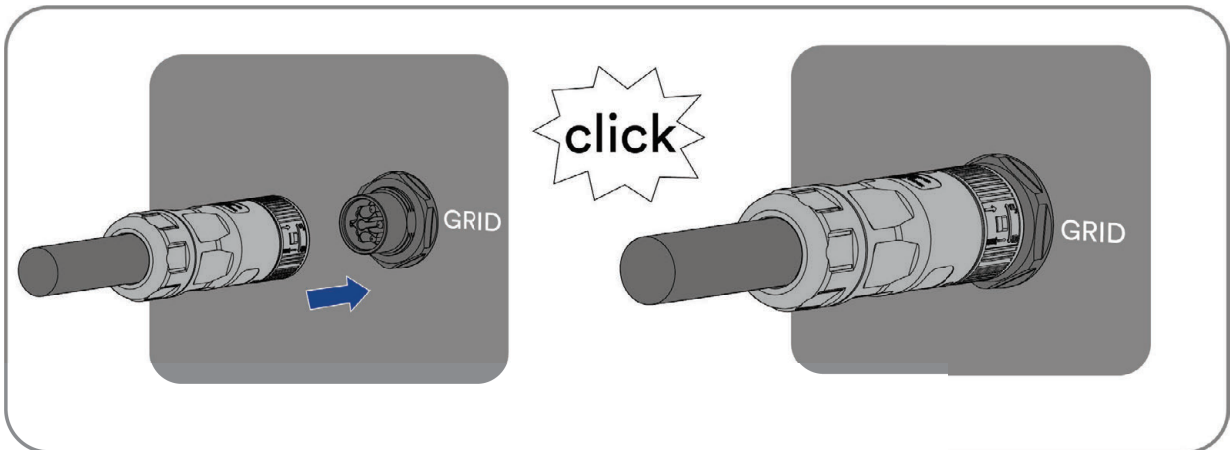

**Complete the installation.**

## 6.4 EPS Load cable connection

### 6.4.1 Requirements for the EPS Load connection

For EPS Load connection requirements, refer to “6.3.1 EPS Load Connection Requirements” for details.

### 6.4.2 Assembling the EPS Load connectors

**Step 1:** Switch off the miniature circuit-breaker or the switch of every energy sources and secure it against being inadvertently switched back on.

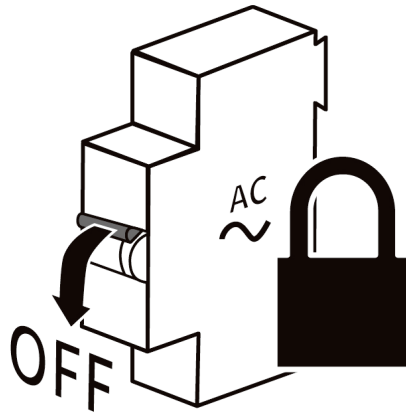

**Step 2:** Split grid connector.

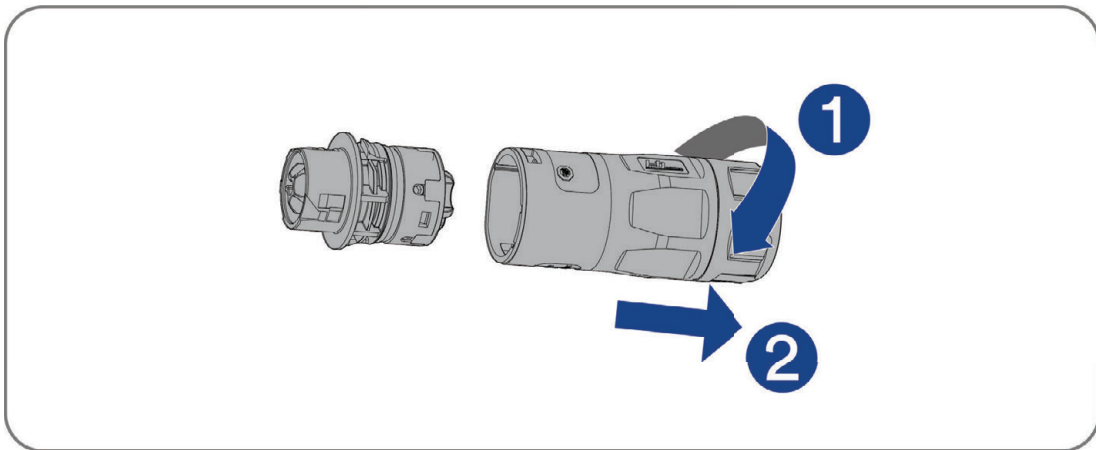

**Step 3:** Crimp the terminals with crimping pliers.

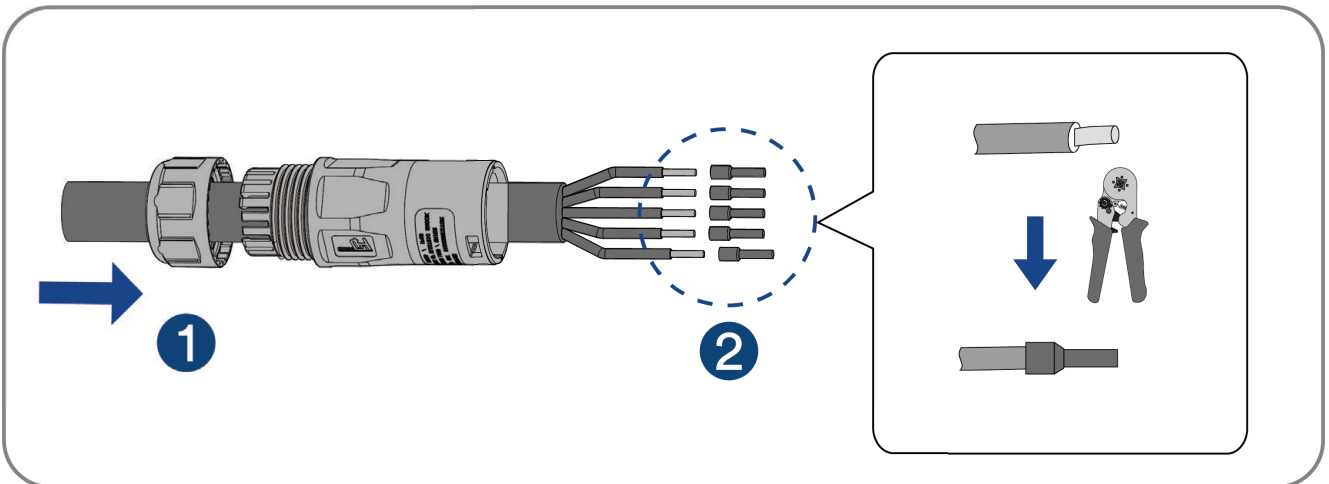

Crimping tool selection and crimping requirements are shown in the following figure:

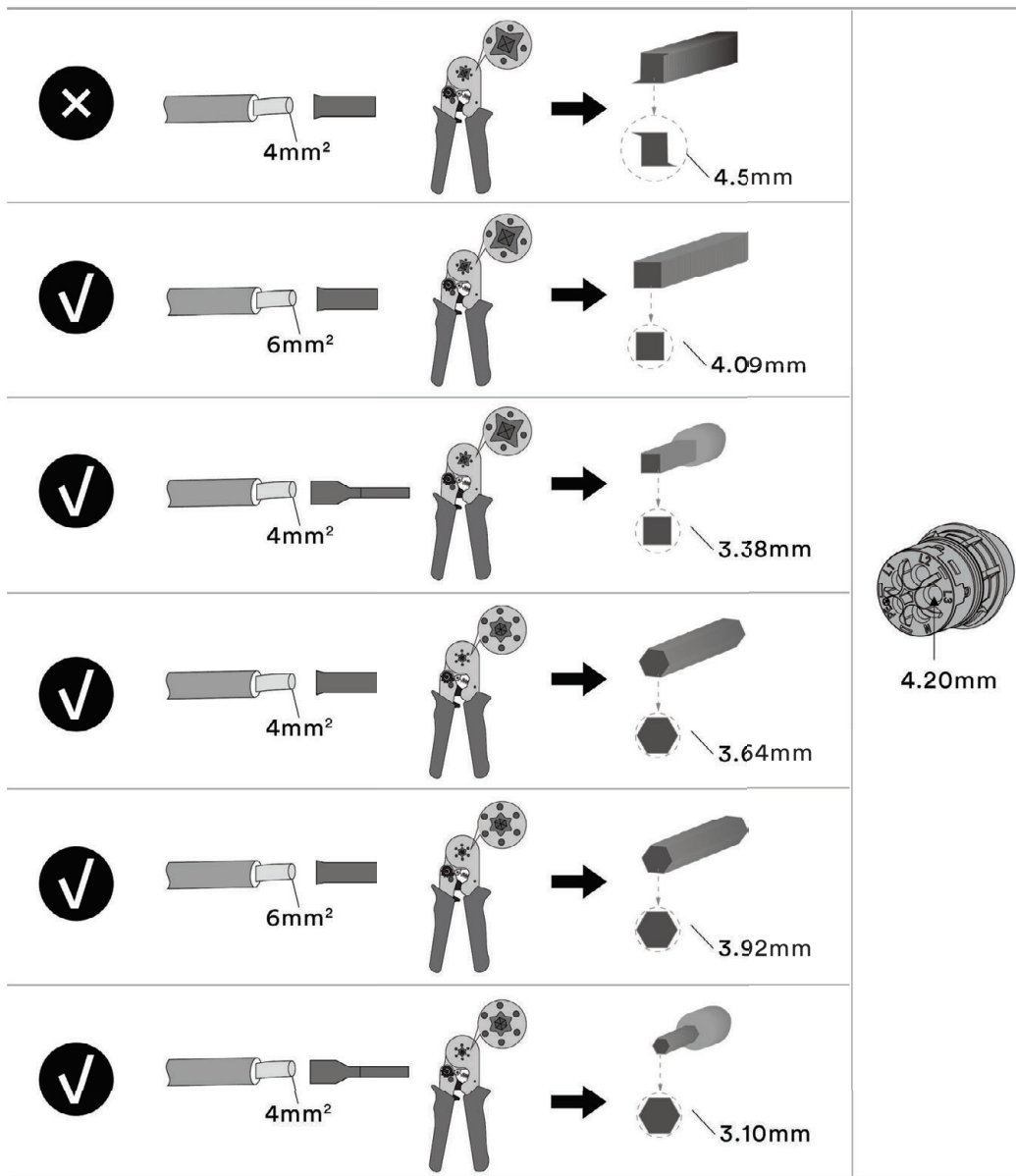

**Step 4:** Set the parts on the cable, insert the terminal holes in sequence. Crimp the wire with an inner hexagon screwdriver and screw the torque  $1.2 \pm 0.1 \text{ N}\cdot\text{m}$ .

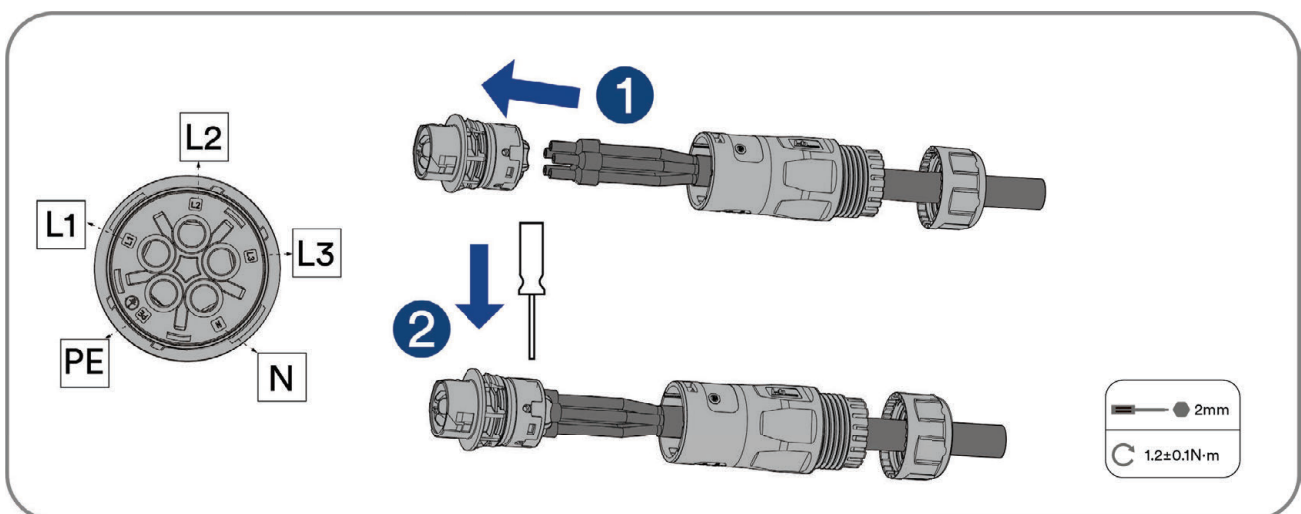

**Step 5:** Insert the main body into the rubber core and hear the “click” sound.



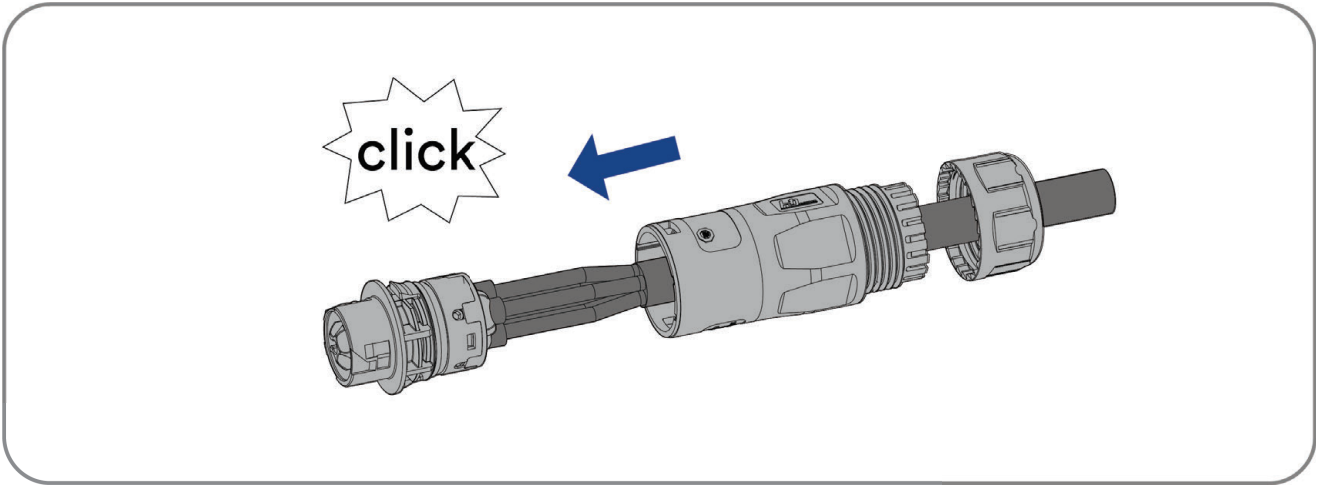

**Step 6:** Tighten the nut with an open-ended wrench (torque  $2.5 \pm 0.5 \text{N}\cdot\text{m}$ ).

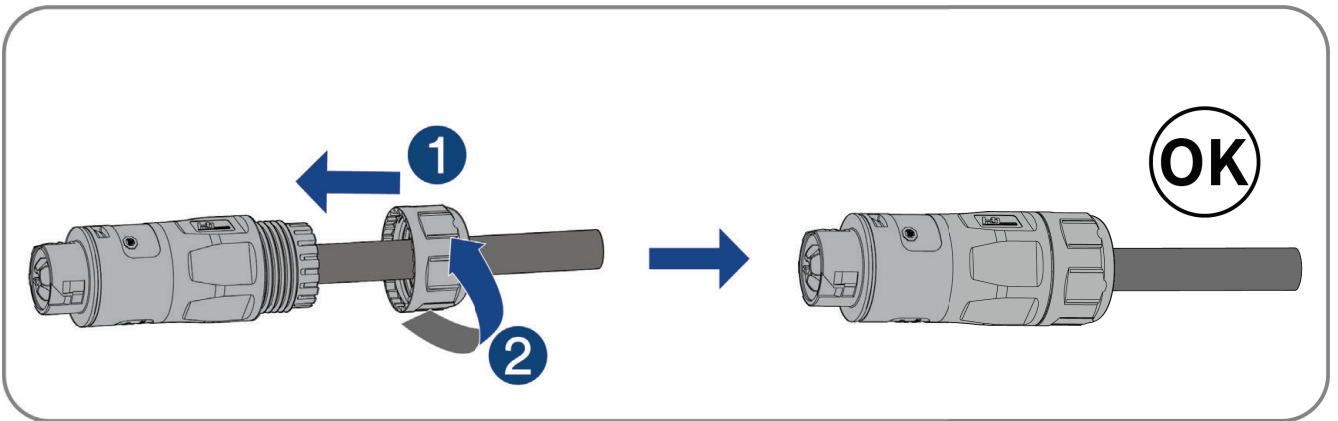

### 6.4.3 Connecting the Back Load connectors

**Step 1:** Remove the dust cover.

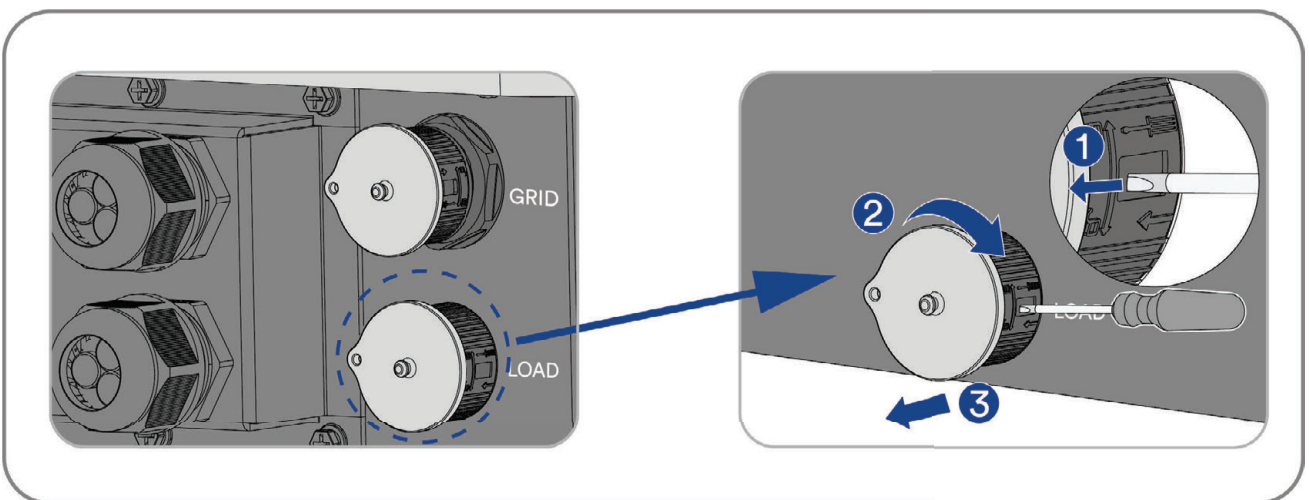

**Step 2:** The installation arrow indicates insertion the female connector, and hear the “click” sound.

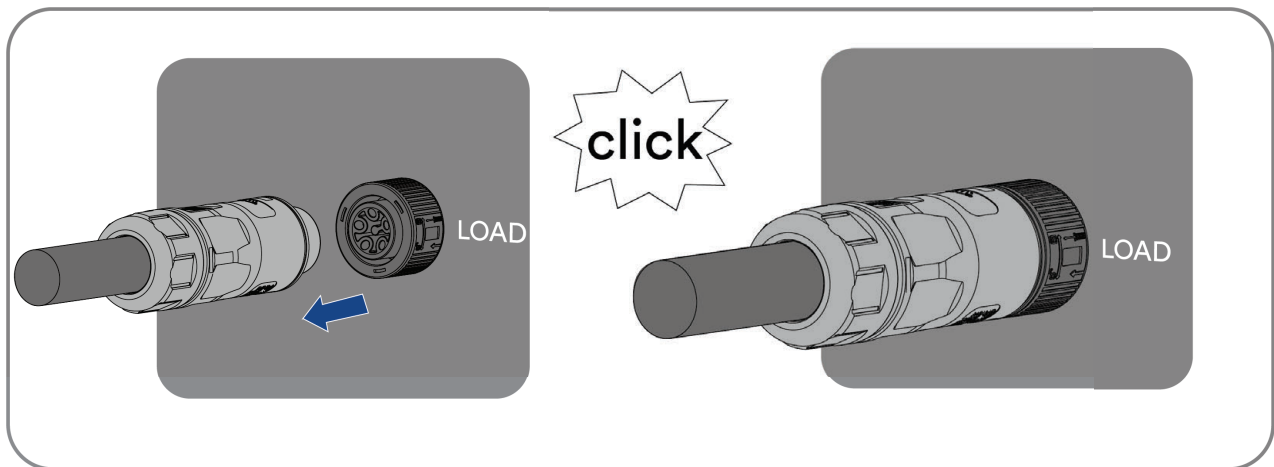

Complete the installation.

## 6.5 DC connection

### 6.5.1 Requirements for the DC connection

#### Requirements for the PV modules per input:

- All PV modules should be of the same type.
- All PV modules should be aligned and tilted identically.
- On the coldest day based on statistical records, the open-circuit voltage of the PV modules must never exceed the maximum input voltage of the inverter.
- The maximum input current per PV module must be maintained and must not exceed the through fault current of the DC connectors.
- The connection cables to the inverter must be equipped with the connectors included in the scope of delivery.
- The thresholds for the input voltage and the input current of the inverter must be adhered to.
- The positive connection cables of the PV modules must be equipped with the positive DC connectors. The negative connection cables of the PV modules must be equipped with the negative DC connectors.

### 6.5.2 Assembling the DC connectors

#### **DANGER**

Danger to life due to electric shock when live components or DC cables are touched!

When exposed to light, the PV modules generate high DC voltage which is present in the DC cables. Touching live DC cables results in death or lethal injuries due to electric shock.

Do not touch non-insulated parts or cables.

Disconnect the product from voltage sources and ensure it cannot be reconnected before working on the device.

Wear suitable personal protective equipment for all work on the product.



For connection to the inverter, all PV module connection cable must be fitted with the DC connectors provided. There may be one of two different type DC connector shipped. Assemble the DC connectors as described in the following.

### Type 1 DC connector:

Assemble the DC connectors as described below. Be sure to observe the correct polarity. The DC connectors are marked with the symbols “+” and “-”.

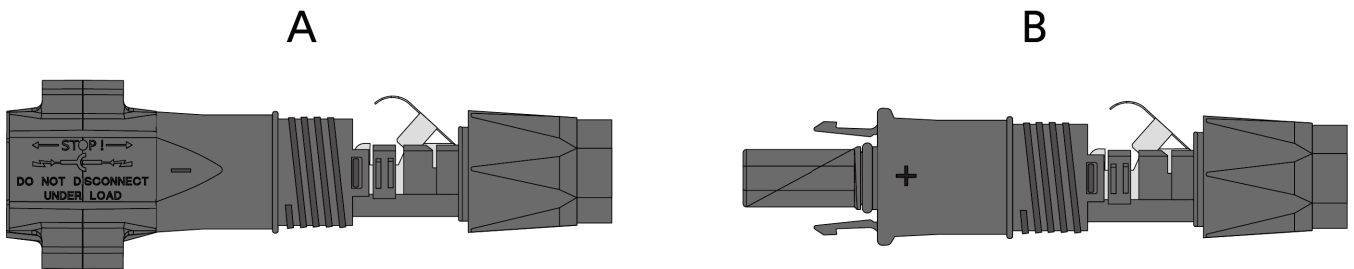

### Cable requirements:

Item	Description	Value
1	Cable type	PV cable
2	External diameter	5-8 mm
3	Conductor cross-section	2.5-6 mm <sup>2</sup>
4	Number of copper wires	At least 7
5	The rated voltage	≥1100v

### Procedure:

**Step 1:** Strip 12 mm off the cable insulation.

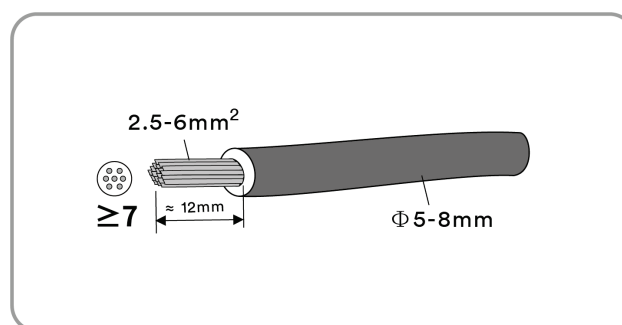

**Step 2:** Crimp the contacts with the corresponding cables. Crimping tool: PV-CZM-61100.

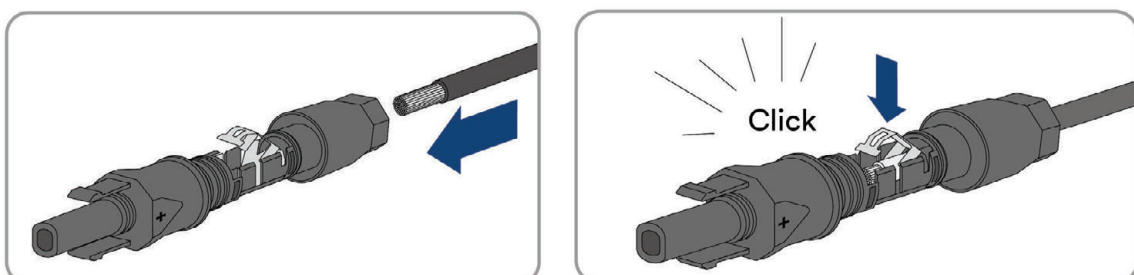



If the stranded wire is not visible in the chamber, the cable is not correctly inserted and the connector must be reassembled. To do this, the cable must be removed from the connector.

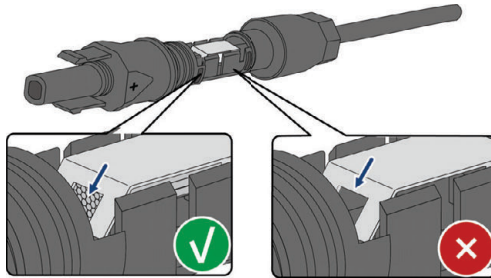

Release the clamping bracket. To do so, insert a screwdriver (blade width: 3.5mm) into the clamping bracket and pry the clamping bracket open.

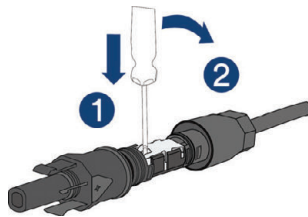

Remove the cable and go back to step 2.

**Step 3:** Push the swivel nut up to the thread and tighten the swivel nut. (SW15, Torque: 2.0Nm)

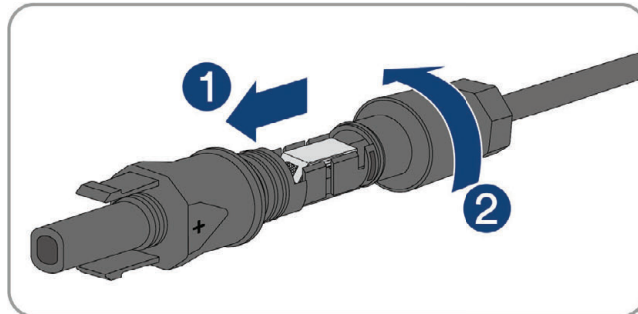

### Type 2 DC connector:

Assemble the DC connectors as described in the following.

Assemble the DC connectors as described below. Be sure to observe the correct polarity. The DC connectors are marked with the symbols “+” and “-”.

A

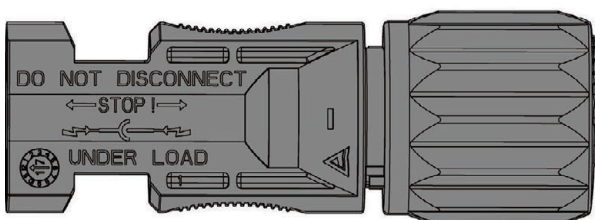

B

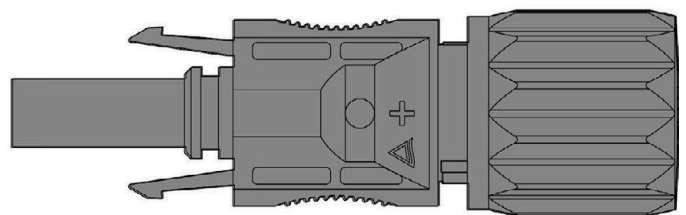

**Cable requirements:**

Item	Description	Value
1	Cable type	PV1-F, UL-ZKLA or USE2
2	External diameter	5-8 mm
3	Conductor cross-section	2.5-6 mm <sup>2</sup>
4	Number of copper wires	At least 7
5	The rated voltage	≥1100v

**Procedure:**

**Step 1:** Strip 12 mm off the cable insulation.

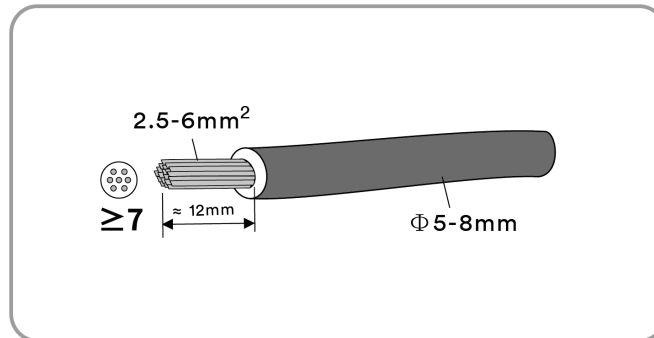

**Step 2:** Assemble the cable ends with the crimping pliers.

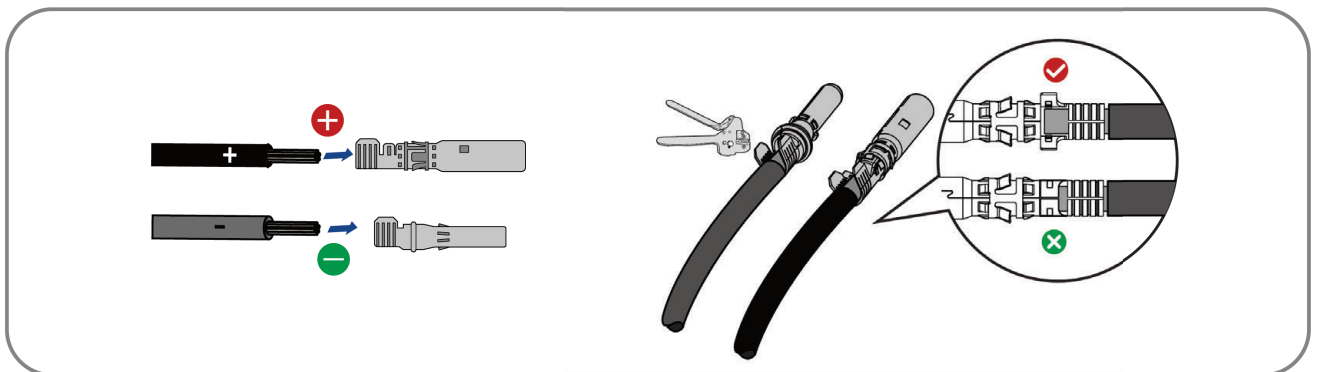

**Step 3:** Lead the cable through cable gland, and insert into the insulator until it snaps into place. Gently pull the cable backward to ensure firm connection. Tighten the cable gland and the insulator (Torque 2.5-3Nm).

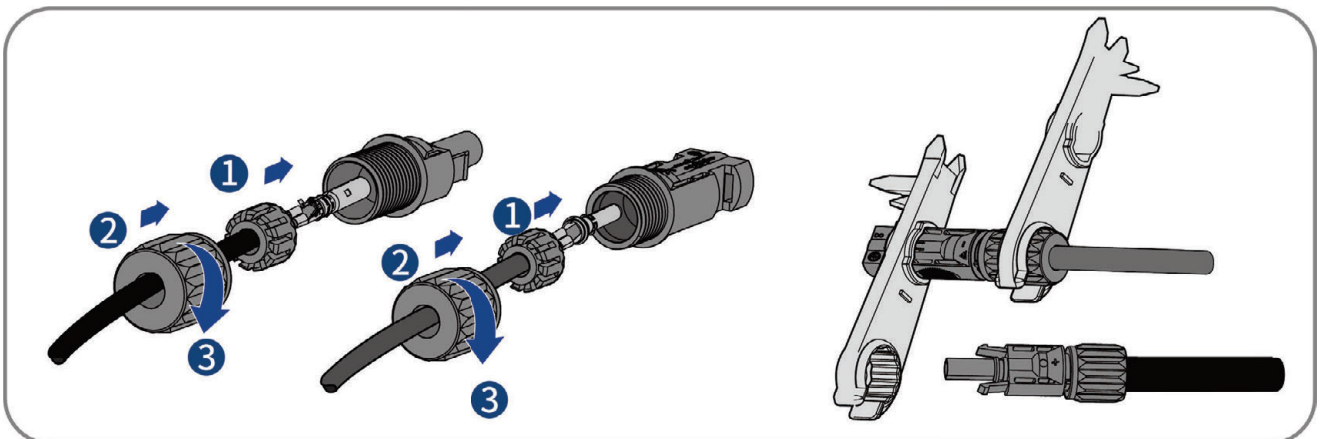

**Step 4:** Ensure that the cable is correctly positioned.

### 6.5.3 Connecting the PV module

#### **DANGER**

Danger to life due to high voltages in the inverter!

When exposed to light, the PV modules generate high DC voltage which is present in the DC cables. Touching live DC cables results in death or lethal injuries due to electric shock..

Before connecting the PV array, ensure that the DC switch is switched off and that it cannot be reactivated.

Do not disconnect the DC connectors under load.

#### **NOTICE**

The inverter can be destroyed by overvoltage!

If the voltage of the strings exceeds the maximum DC input voltage of the inverter, it can be destroyed due to overvoltage.

All warranty claims become void.

Do not connect strings with an open-circuit voltage greater than the maximum DC input voltage of the inverter.

Check the design of the PV system.

#### **Procedure:**

**Step 1:** Ensure that the individual miniature circuit-breaker is switched off and ensure that it cannot be accidentally reconnected.

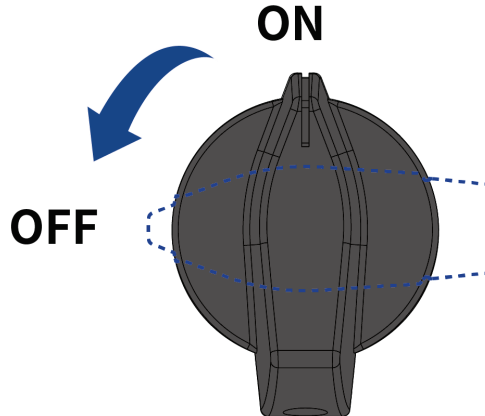

**Step 2:** Ensure that the DC switch is switched off and ensure that it cannot be accidentally reconnected.

**Step 3:** Ensure that there is no ground fault in the PV array.

**Step 4:** Check whether the DC connector has the correct polarity.

If the DC connector is equipped with a DC cable having the wrong polarity, the DC connector must be reassembled. The DC cable must always have the same polarity as the DC connector.

**Step 5:** Ensure that the open-circuit voltage of the PV array does not exceed the maximum DC input voltage of the inverter.

**Step 6:** Connect the assembled DC connectors to the inverter until they audibly snap into place.

**Type 1 DC connector:**

- Connect the assembled DC connectors to the inverter.

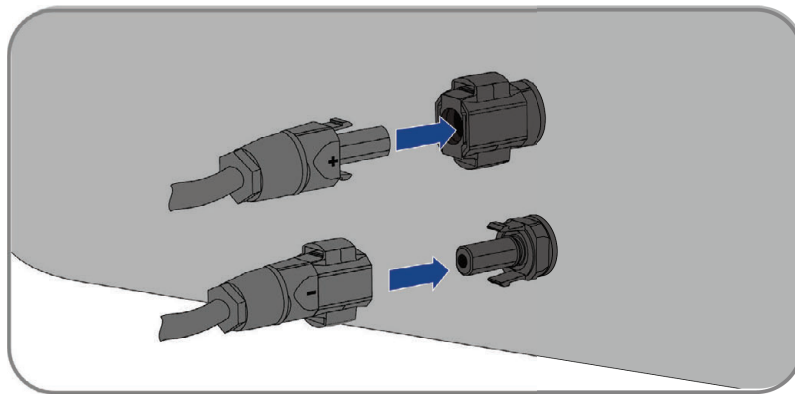

- For unused DC connectors, push down the clamping bracket and push the swivel nut up to the thread. Insert the DC connectors with sealing plugs into the corresponding DC inputs on the inverter.

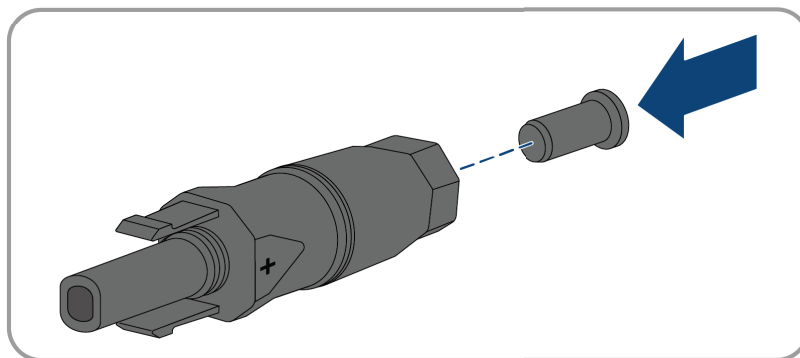
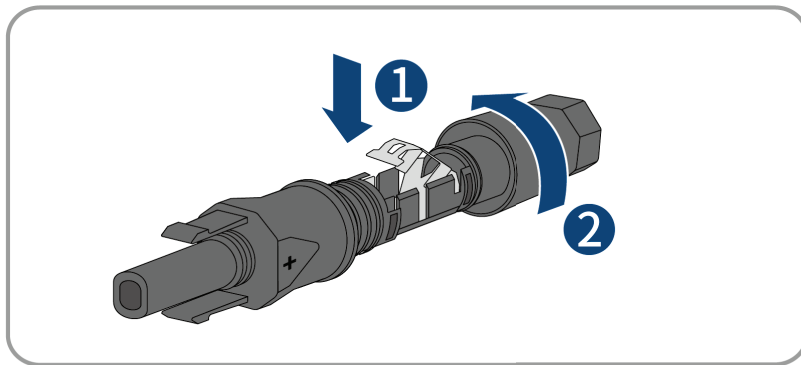

- Insert the DC connectors with sealing plugs into the corresponding DC inputs on the inverter.

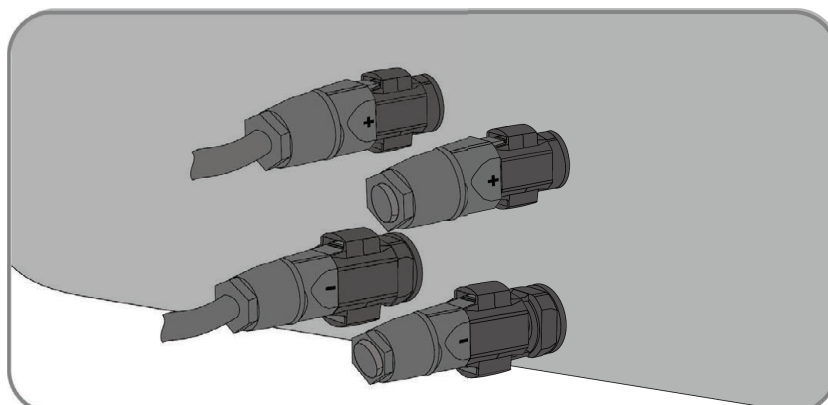

**Type 2 DC connector:**

- Connect the assembled DC connectors to the inverter.

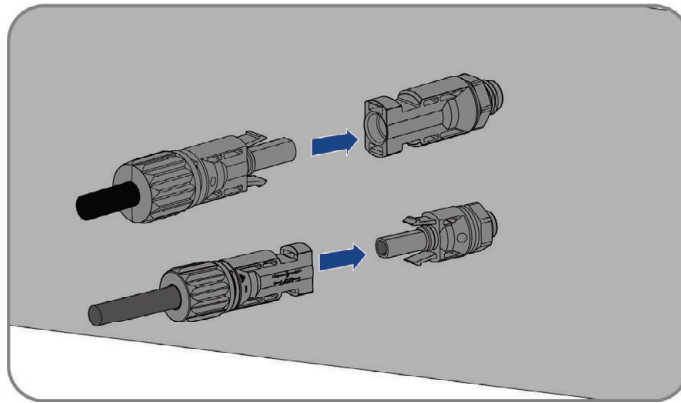

- For unused DC connectors, push down the clamping bracket and push the swivel nut up to the thread. Insert the DC connectors with sealing plugs into the corresponding DC inputs on the inverter.

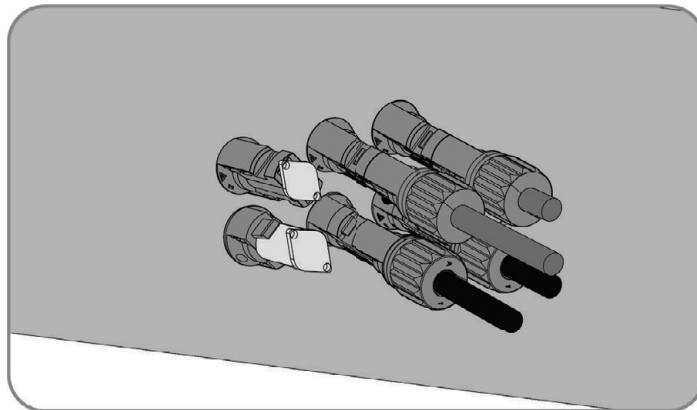

Check the positive and negative polarity of the PV strings, and connect the PV connectors to corresponding terminals only after ensuring polarity correctness. (The graph uses the type 2 connector as an example only.)

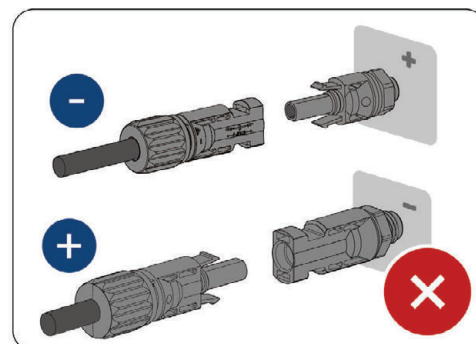
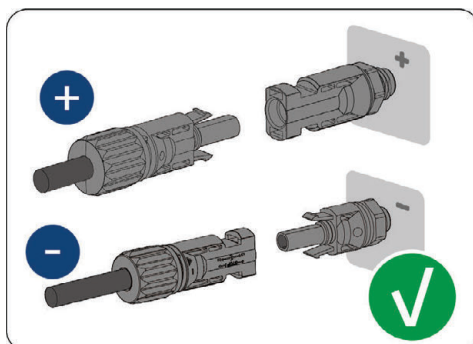

**Step 7:** Ensure that all DC connectors and the DC connectors with sealing plugs are securely in place.

**Complete the installation.**



## 6.6 Battery connection

### 6.6.1 Requirements for the Battery connection

Assemble the Battery connectors as described in the following.

Before connect battery, it is important to make sure the battery is in Hybrid-battery compatibility list, please download the list in the webside: <https://solplanet.net/products/asw-5-12k-h-t2-t3-series/>.



For Australia market, please download the list in the webside: <https://solplanet.net/au/products/asw-5-12k-h-t2-t3-series/>.

Assemble the Battery connectors as described below. Be sure to observe the correct polarity. The Battery connectors are marked with the symbols “+” and “-”.

**A**



**B**

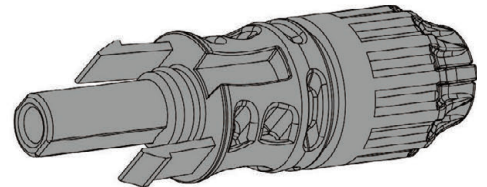

#### Cable requirements:

Item	Description	Value
1	External diameter	6.4-8.5 mm
2	Conductor cross-section	6mm <sup>2</sup> /10AWG or 10 mm <sup>2</sup> /8AWG
3	Number of copper wires	At least 7
4	The rated voltage	≥1100v

### 6.6.2 Assembling the Battery connectors

#### Procedure:

**Step 1:** Strip 6-7.5 mm off the cable insulation.

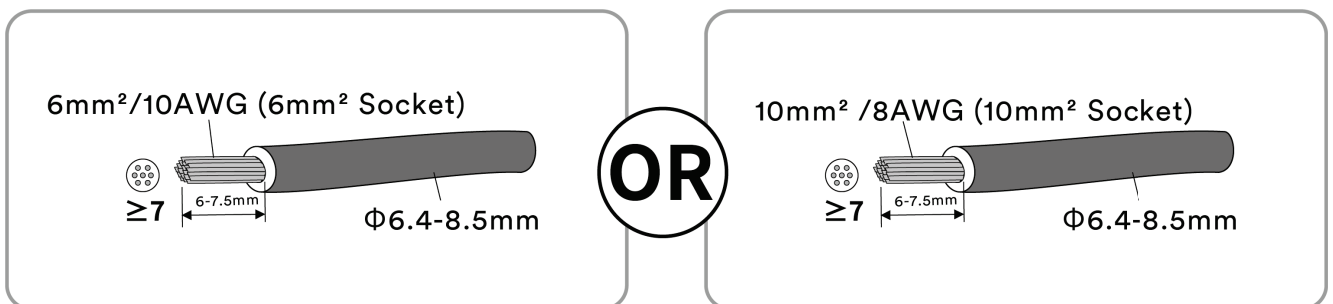

**Step 2:** Assemble the cable ends with the crimping pliers.

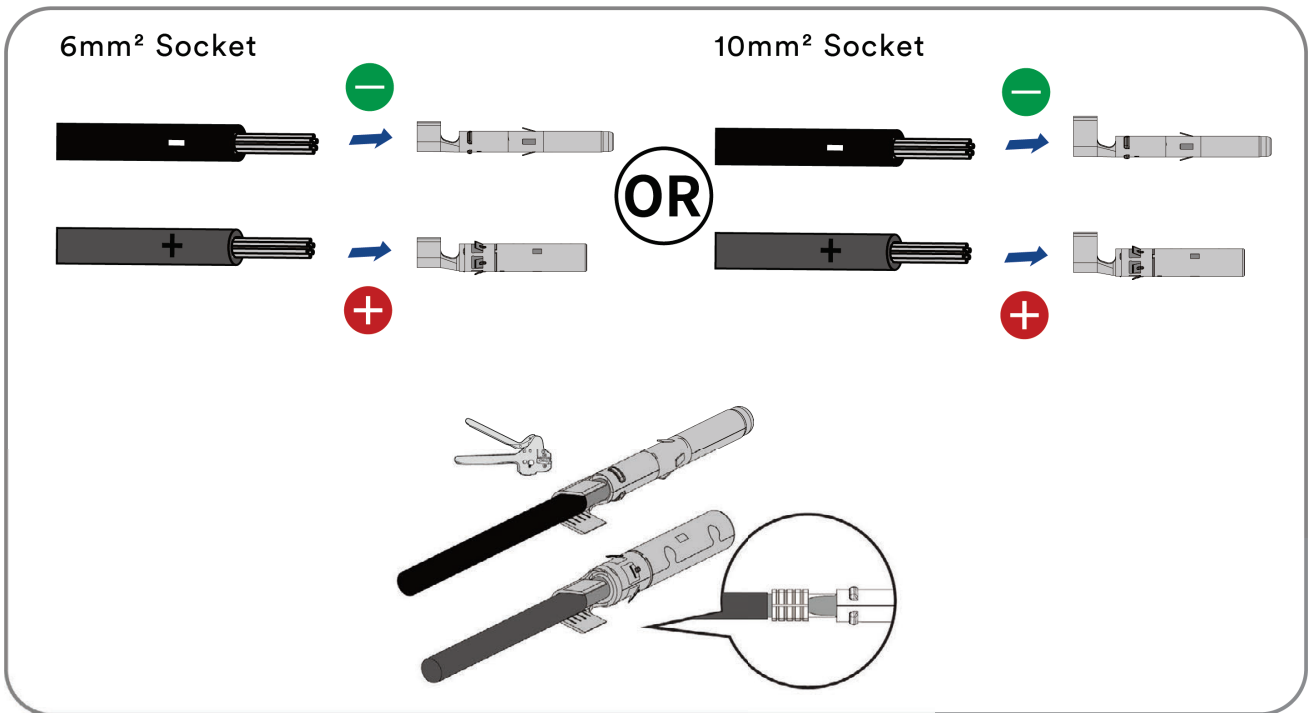

**Step 3:** Lead the cable through cable gland, and insert into the insulator until it snaps into place. Gently pull the cable backward to ensure firm connection. Tighten the cable gland and the insulator (Torque 4Nm).

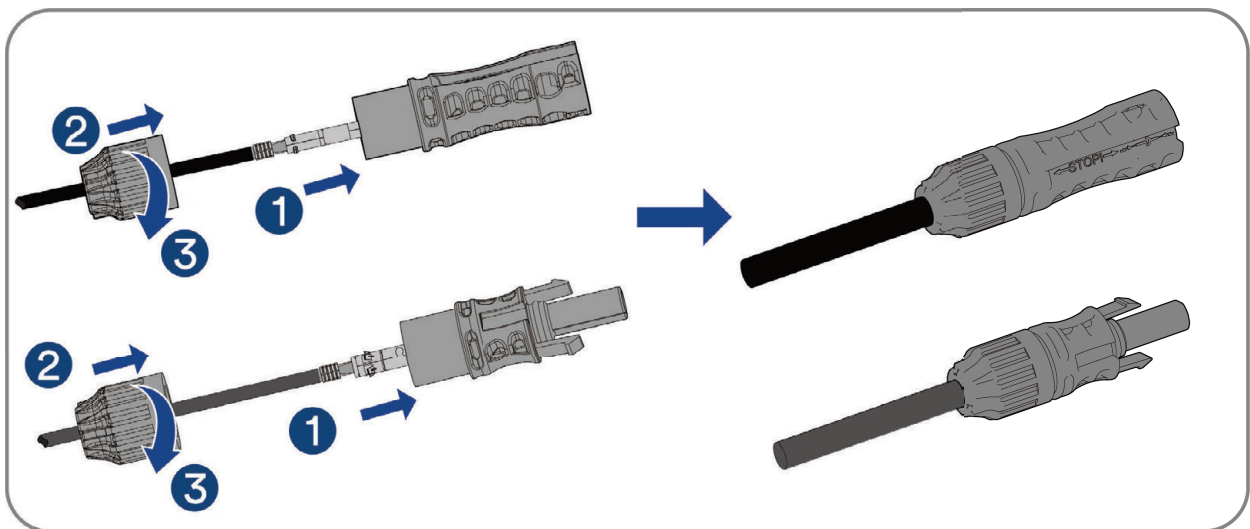

**Step 4:** Ensure that the cable is correctly positioned.

**Complete the installation.**

### 6.6.3 Connecting the Battery connectors

**Step 1:** Remove the dust and waterproof cover of the BMS connector on the inverter and retain it.

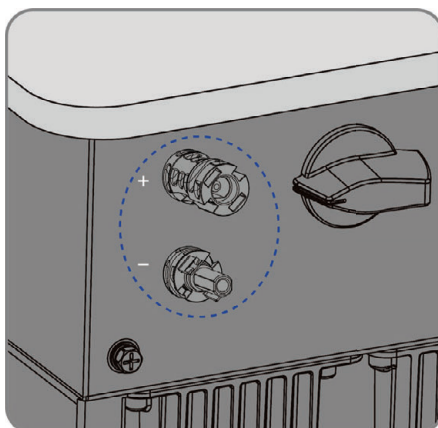

**Step 2:** Connect the assembled DC connectors to the inverter.

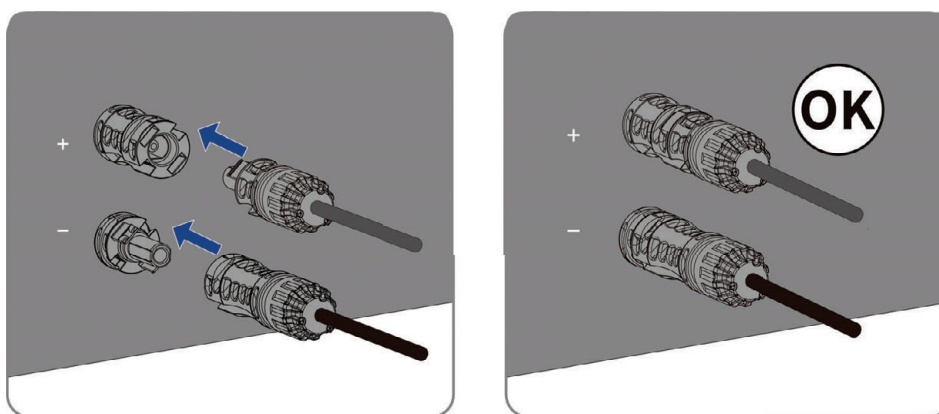

Complete the installation.

## 6.7 Ai-Dongle connection

**Procedure:**

**Step 1:** Rotate the nut, take out the sealing ring, hold the locking structure, and take out the wiring terminal.

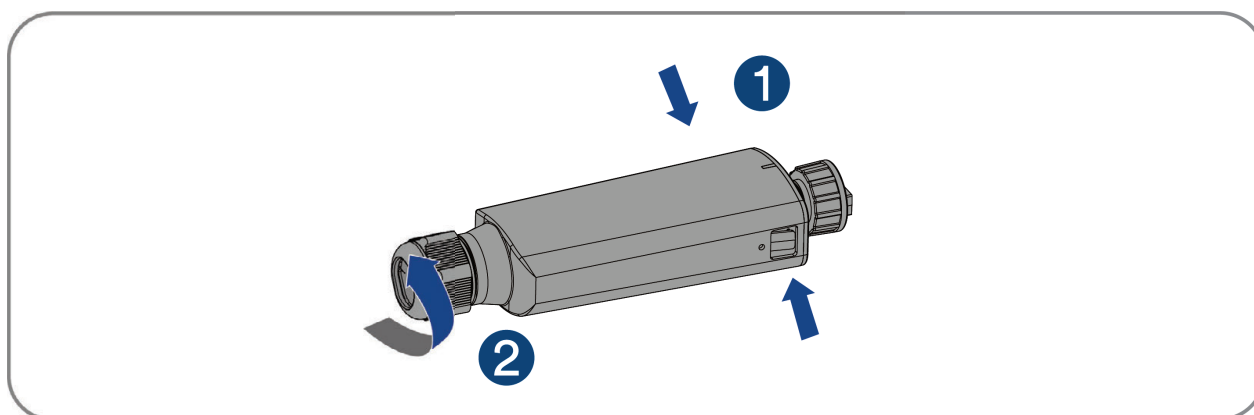

**Step 2:** Lock the communication cable to the wiring terminal according to the sequence shown in the following figure.

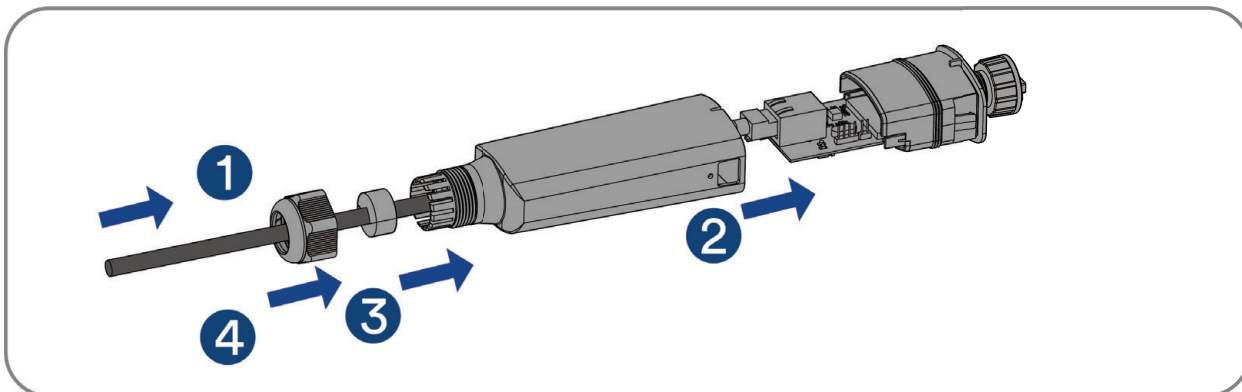

**Step 3:** Insert the wiring terminal into the sealing head, adjust the communication cable, insert the sealing ring, and lock nut.

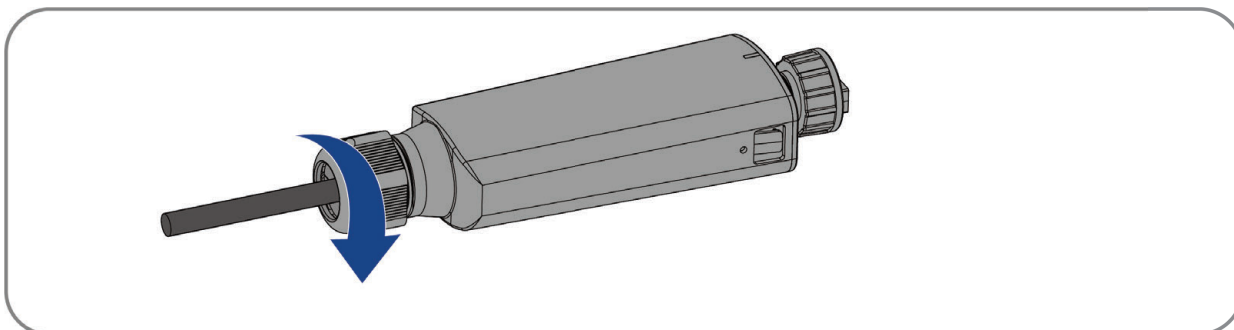

**Step 4:** Remove the dust and waterproof cover of the Ai-Dongle on the inverter and retain it.

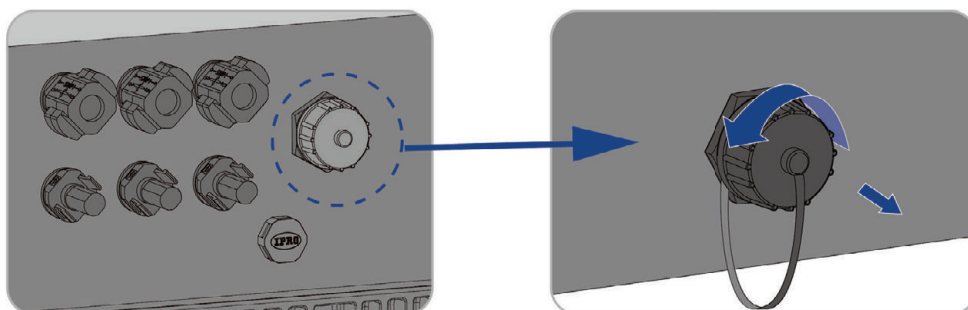

**Step 5:** Attach the Ai-Dongle to the connection port in place and tighten it into the port by hand with the nut in the modular. Make sure the modular is securely connected and the label on the modular can be seen.

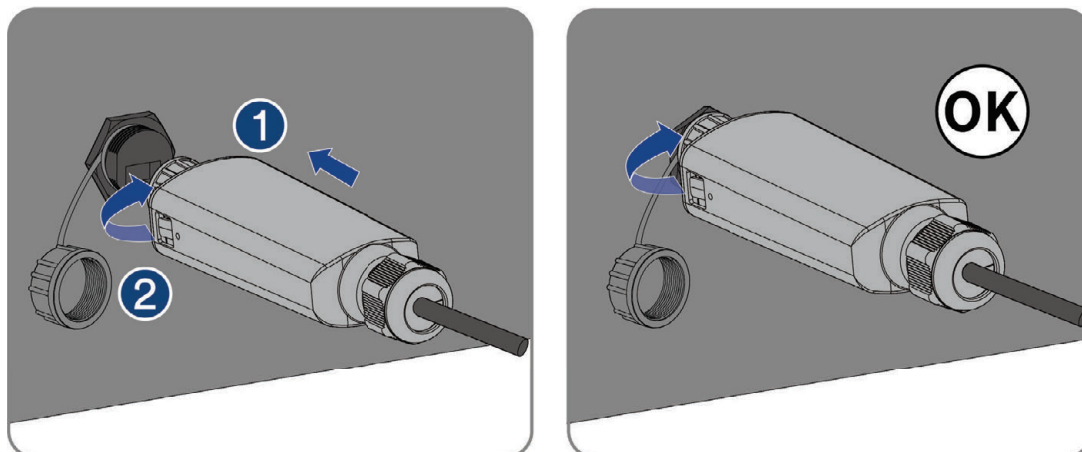

## NOTICE

Rotating the communication modular will damage the communication modular!

The communication modular is protected by locking nuts to protect the reliability of the connection. If the body of the communication modular is rotated, the communication modular will be damaged.

It can only be locked by a nut.

Do not rotate the communication modular body.

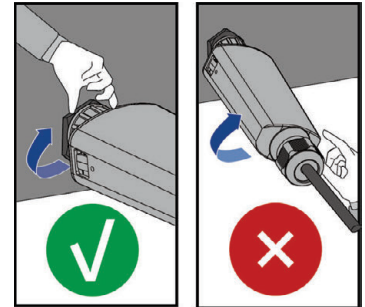

Complete the installation.

## 6.8 Communication equipment connection

### 6.8.1 Communication interface description

The inverter is equipped with a communication interface, which is used to connect communication cables such as lithium battery, electricity meter and parallel machine. The interface configuration of the communication interface is shown in the following figure.

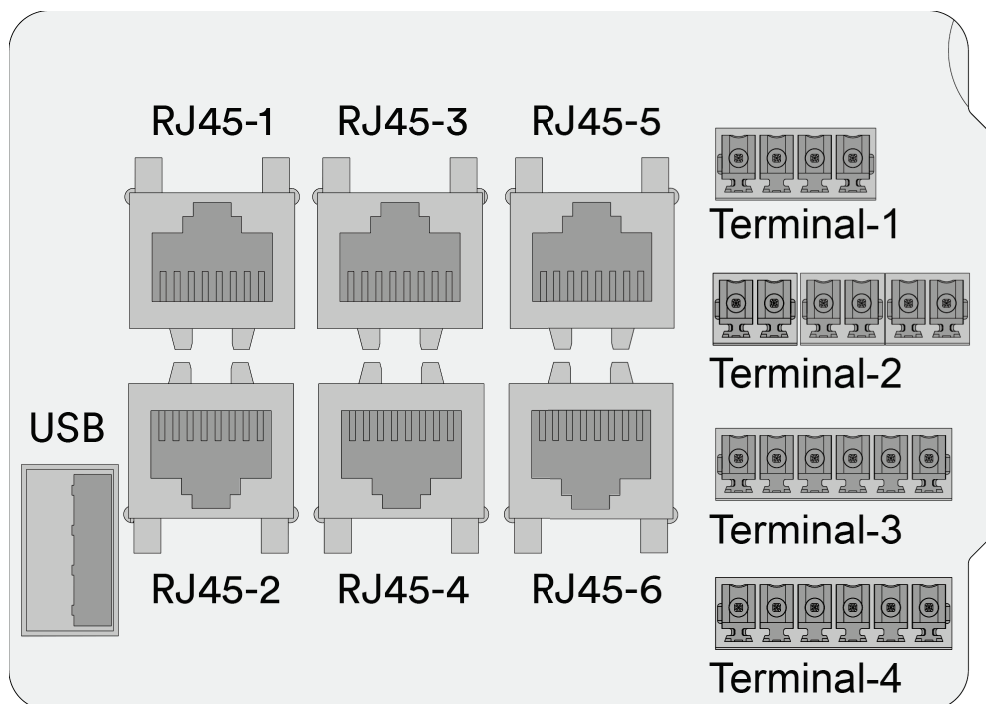

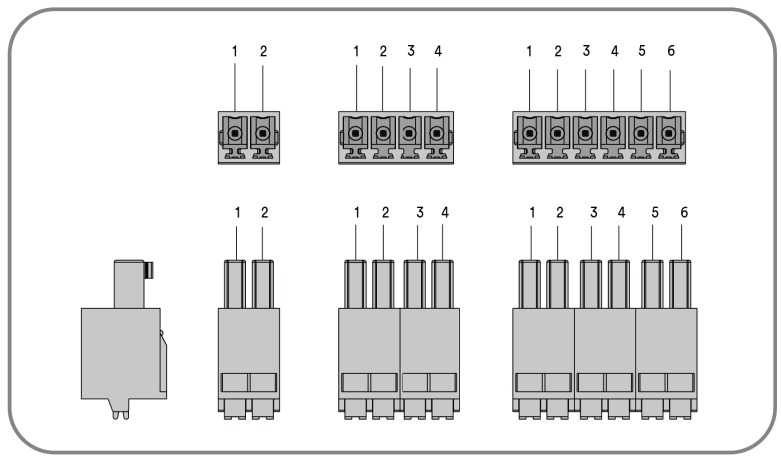
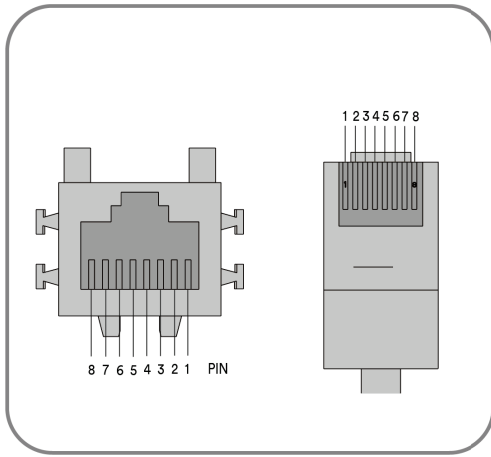

Object	Description	Terminal	PIN definition							
			1	2	3	4	5	6	7	8
RJ-45-3	Monitor	COM2	RS-485A	RS-485B	GND	X	X	X	RS-485A	RS-485B
RJ-45-4	BMS	COM5	X	GND	X	CANAH	CANAL	X	RS-485A	RS-485B

Object	Description	Terminal	PIN definition					
			1	2	3	4	5	6
Terminal-2	\	6pin	Smart Meter			\	NS-protection (network and system protection) Device	
			RS485A	RS485B	Positive		Negative	
Terminal-3	DI*4/DRM0	6pin	Ripple Control Receiver Device				DRMS Device	
			DI_4	DI_3	DI_2	DI_1	REF GEN/0	COM LOAD/0 or GND
Terminal-4	CT	6pin	Current Transformer L1(U)		Current Transformer L2(V)		Current Transformer L3(W)	
			Red	Black	Red	Black	Red	Black

Com port	Description	Function
USB	USB port	The firmware can be storage in the USB disk. The product will update automatically after the USB disk insert to USB interface.
RJ45-1 RJ45-2 RJ45-5 RJ45-6	RS485 port	The RS485 interfaces used to the product parallel operation.
RJ45-3	Monitor device	The PIN1、 PIN2 of RS485 interface used to connect the product to the third-party monitor device. If you don't want to use Ai-Dongle, the third-party monitor device can be used.
RJ45-4	BMS communication port	The RS-485/CAN interface used to connect the BMS (Battery Management System) of the battery. If the communication interface of the BMS is CAN interface, the pins for CAN interface can be chosen to connect, otherwise the pins for RS485 interface can be chosen to connect.
Terminal-1	Multifunction Relay	The product is equipped with two multifunction relays as standard. The multifunction relays can be configured for the operating mode used by a particular system. For more information, please contact AISWEI service.

Terminal-2	Smart Meter PT100 Temperature sensor NS-protection (network and system protection) Device	Terminal 2 can be used to connect the smart meter, PT100 temperature sensor and NS-protection (network and system protection) device. The PIN definition is shown as above table.
Terminal-3	Ripple control receiver device DRMs device	Terminal 3 can be used to connect the ripple control receiver and DRMs device. The PIN definition is shown as above table. Especially the PIN 6 (GND) is a common port for both devices.
Terminal-4	current transformer	Terminal 4 can be used to connect three current transformers. The PIN definition is shown as above table.

## 6.8.2 Communication cable connection

**Step 1:** Remove the communication cover.

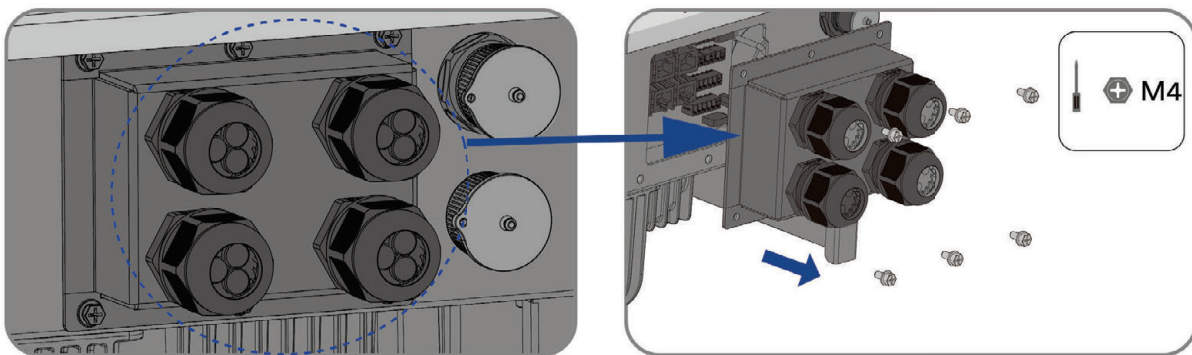

**Step 2:** Route the communication cable through the communication cover and crimp the wiring terminal.

The sequence of the crimping wires of the wiring terminals is shown in the following figure:

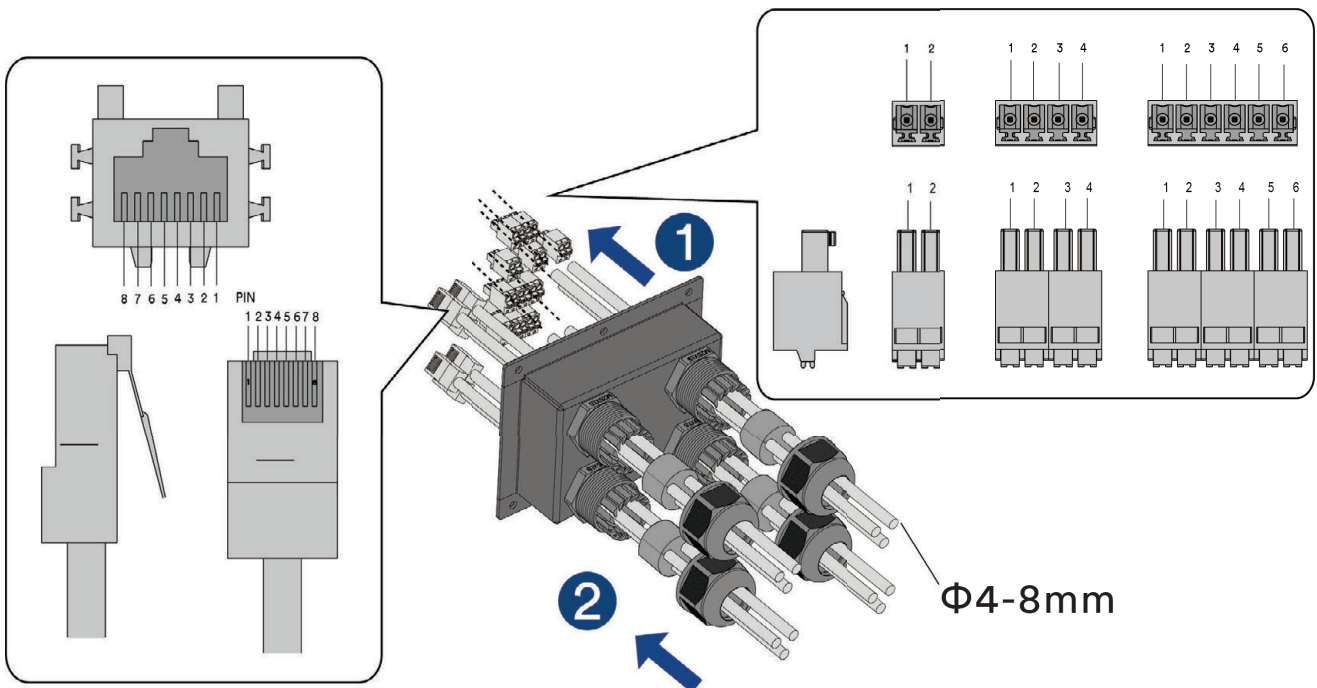

**Step 3:** Connect the communication cable crimped to the corresponding communication port.

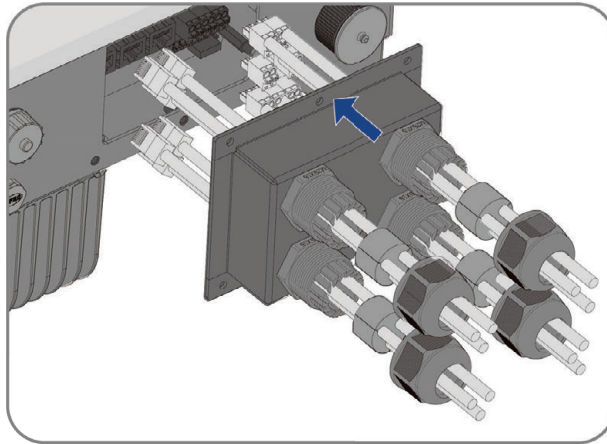

**Step 4:** Install the communication cover on the inverter.

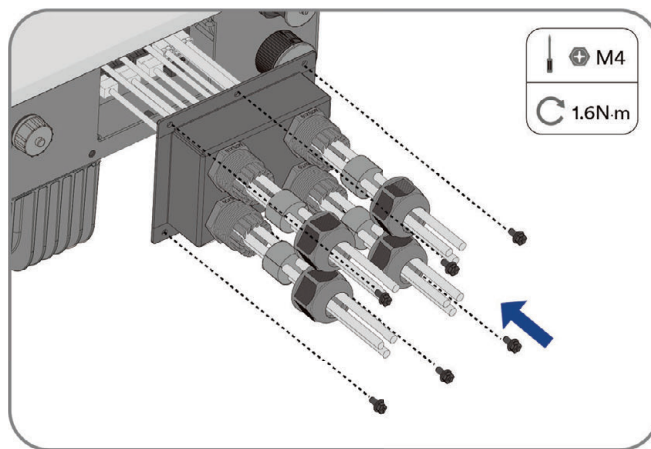

**Step 5:** Tighten the cable gland nuts.

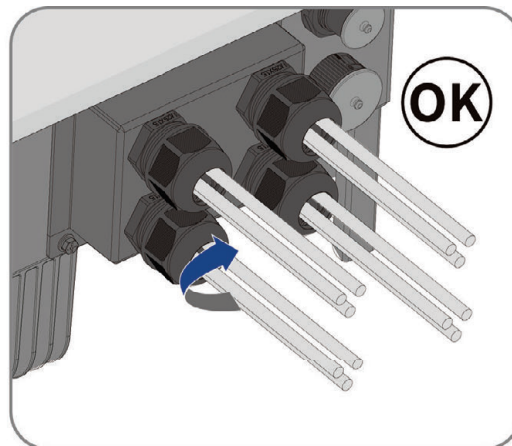
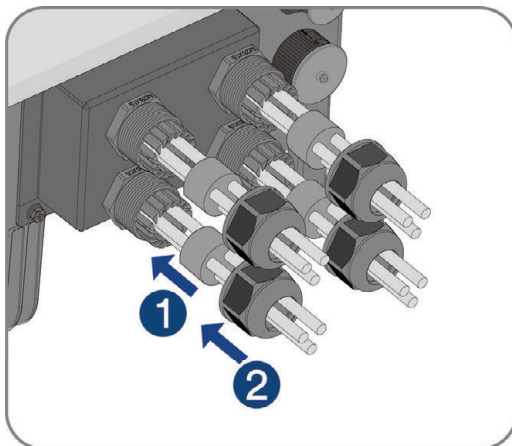

**Complete the installation.**



### 6.8.3 Current Transformer connection

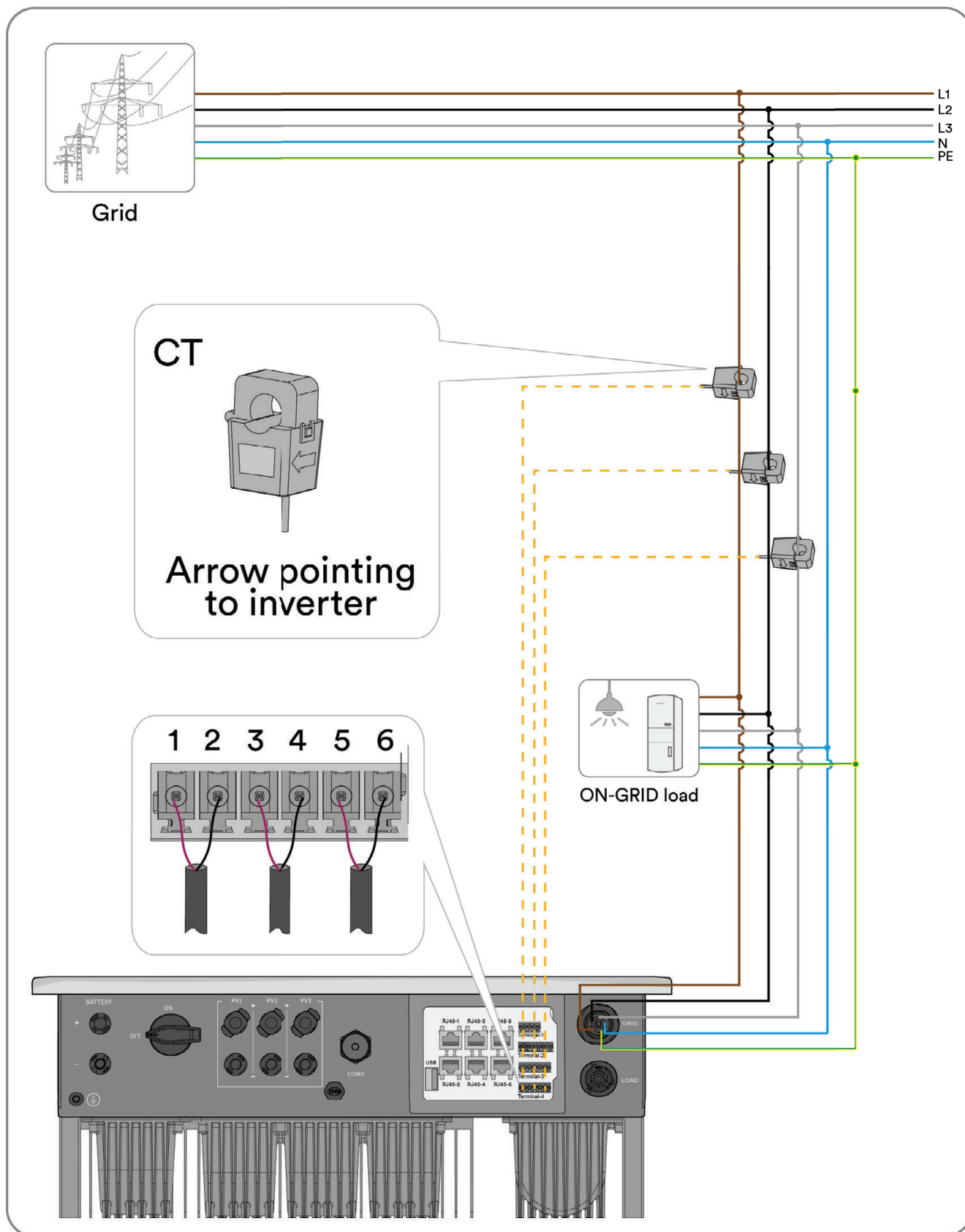

### 6.8.4 Smart meter connection

The grid structure supported by the product is TN-S. For other grid types, please refer to 4.4.

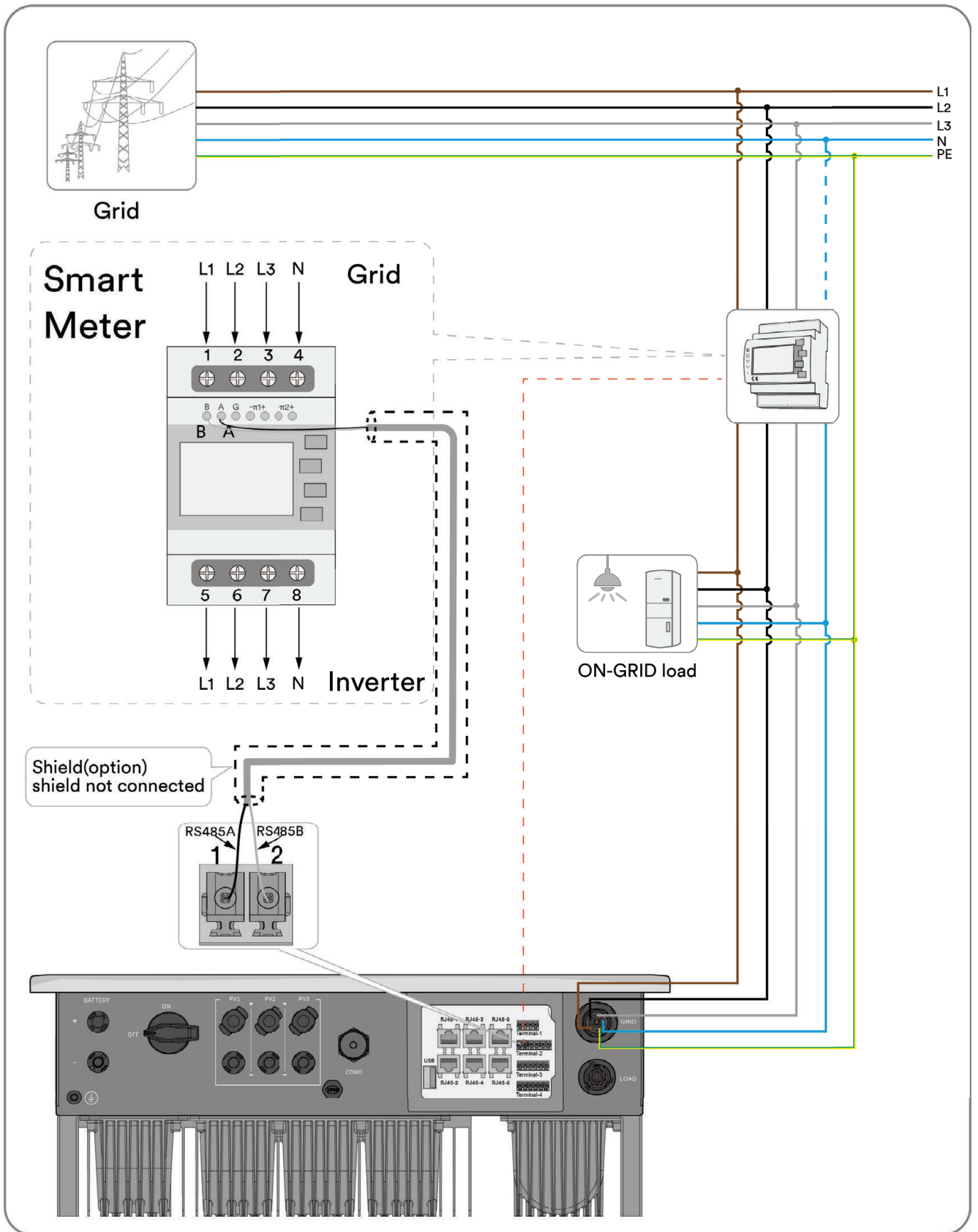

## 7 Commissioning and operating

### 7.1 Inspection before commissioning

#### CAUTION

Danger to life due to high voltages on DC conductors!

When exposed to sunlight, the PV array generates dangerous DC voltage which is present in the DC conductors. Touching the DC and AC conductors can lead to lethal electric shocks..

Only touch the insulation of the DC cables.

Only touch the insulation of the AC cables.

Do not touch ungrounded PV modules and brackets.

Wear personal protective equipment, such as insulating gloves.

Check the following items before starting the inverter:

- Make sure the inverter DC switch and external circuit breaker are disconnected.
- Make sure the inverter has been correctly mounted with wall bracket.
- Make sure nothing is left on the top of the inverter.
- Make sure the communication cable and AC connector have been correctly wired and tightened.
- Make sure the inverter's exposed metal surface has a ground connection.
- Make sure the DC voltage of the strings does not exceed the permitted limits of the inverter.
- Make sure the DC voltage has the correct polarity.
- Make sure that the insulation resistance to ground is greater than the insulation resistance protection value.
- Make sure the grid voltage at the point of connection of the inverter complies with the permitted value of the inverter.
- Make sure the AC circuit breaker complies with this manual and all applicable local standards.

### 7.2 Commissioning procedure

If all of the items mentioned above meet the requirements, proceed as follows to start up the inverter for the first time.

**Step 1:** Turn the DC switch of the inverter to "ON" position and start battery, but keep the breakers on EPS and grid port to "OFF" position.

**Step 2:** Connect the inverter with soplant APP, For details, please refer to 8.4. Then set grid code, operation mode(refer to 4.7), meter or CT type, battery model and SOC limit refer to 8.4.

**Step 3:** Turn the breakers on EPS and grid port to "ON" position. If the irradiation and grid conditions meet requirements, the inverter will operate normally.

**Step 4:** Observe the LED indicator to ensure inverter operates normally, check the inverter and battery parameters in APP.

## 8 Solplanet APP

### 8.1 Brief introduction

The Solplanet App can establish communication connection to the inverter via the WLAN, there by achieving near-end maintenance on the inverter. Users can view inverter information and set parameters through the App.

### 8.2 Download and install

Scan the following QR code to download and install the App according to the prompt information.



Android



iOS

### 8.3 Create an account

If you do not have an account, you need to register a new account first.

#### Procedure:

**Step 1:** Open Solplanet App to enter the login screen, and tap “Do not have an account” to enter the next screen.

**Step 2:** The user groups “Business user” and “End user” need be selected according to your identity, and tap “Next step”.



The end user and the business user have the different permissions for setting parameters.

The end user only can set the parameter during commissioning. The business user has more permissions, but they need submit more identity authentication documents.

**Step 3:** Enter the right mobile phone number (Via SMS) or E-mail address (Via mail). And tap the “Send verification code”

**Step 4:** Enter the correct verification code to automatically enter the next page.

**Step 5:** Set the password and click “Register” to complete the registration.

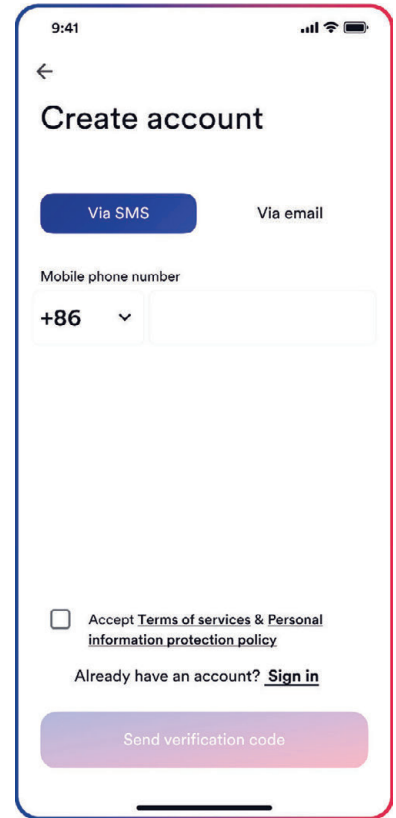
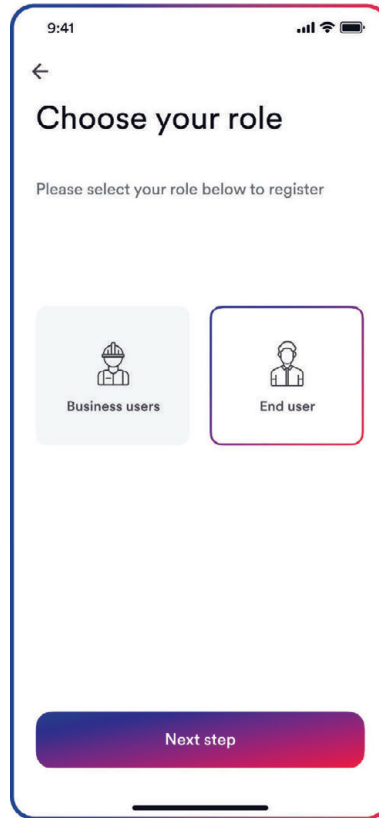
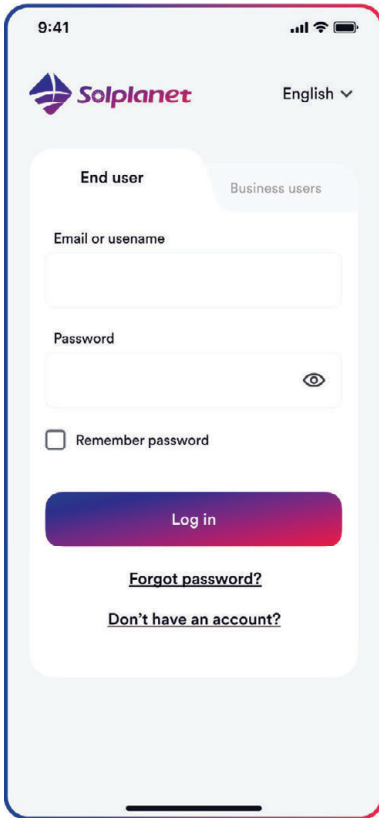

Step 1

Step 2

Step 3

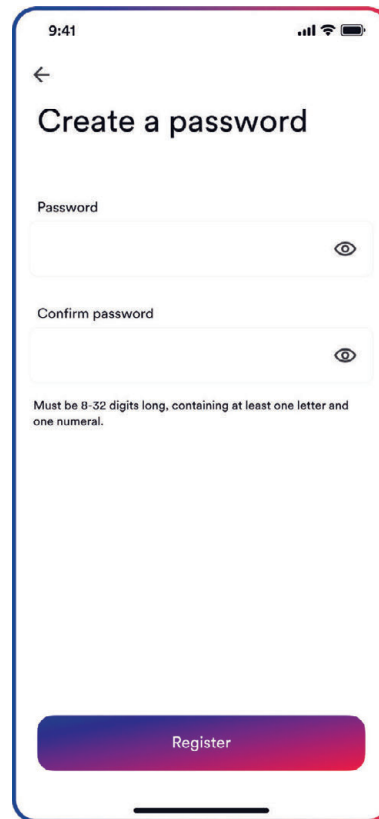
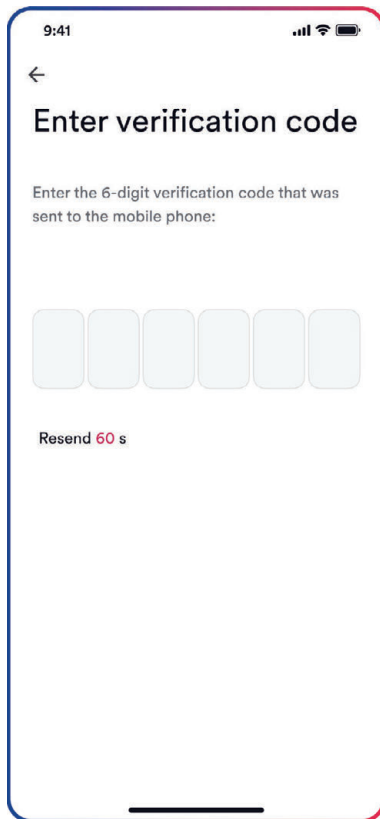

Step 4

Step 5

## 8.4 Create a plant

### Procedure:

**Step 1:** Open Solplanet App to enter the login screen, enter the account name and password, and tap “Log in” to enter the next screen.

**Step 2:** Tap the symbol “+” to enter the next screen, and tap “Create or modify a plant”, then the camera of the mobile automatically turns on, and scan the QR code of the Ai-dongle to enter the next screen, tap “Create new plant” to the next screen.

**Step 3:** Enter the PV plant information in all fields marked with a red asterix, and tap “Create” to enter the next screen.

**Step 4:** After the planet created, tap “Add dongle to the plant”, and tap “Add to plant” to the next screen.

**Step 5:** Tap the inverter serial number that matches your inverter, then the setting parameter can be set. The detail description can be found at section 8.5.



The grid code should be chosen at this step. And the parameters also should be set if the grid company has the different requirements.

**Step 6:** The Energy Management shall be set here. Tap “Energy storage settings” to the next page, then tap “Battery settings” to select the battery model, battery number and choose the energy management model. After the parameter configuration, tap “Confirm” and tap the left arrow to go back the inverter list page. Then tap “Next step” to enter the next page.



The battery discharge minimum is valid only in grid-connected mode, and the off-grid default is 10%.

**Step 7:** The parameter of the “Export Power Control” can be set, and tap “Save” after the parameter configuration. Then tap “Nest step” to enter the next page.

**Step 8:** Tap “Continue”, and choose WiFi network from the list, and enter WiFi network password. Then tap “continue” to enter the next step.

**Step 9:** Observe whether the Led blue light of the dongle stays on. If it is always on, it means that the network configuration is successful, and you can tap “Complete” to complete the configuration. Otherwise, you need to go back to the previous step and re-enter the Wi-Fi password.

**Step 10:** Now the new plant have been created. Tap the plant to review the information of the plant.

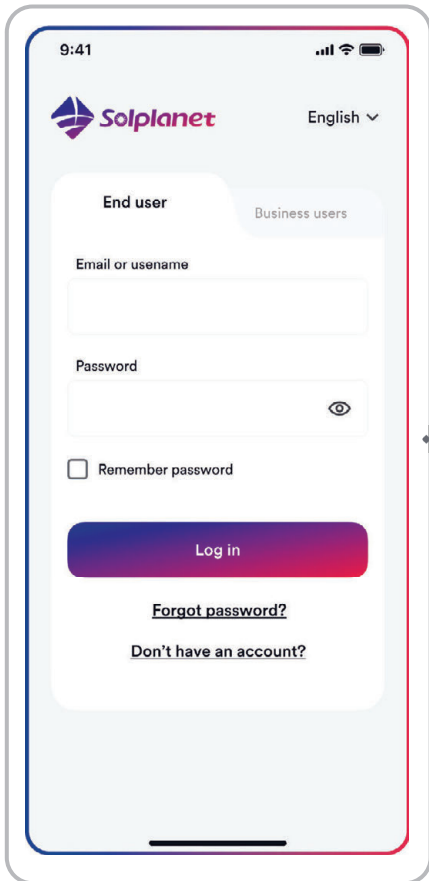

Step 1

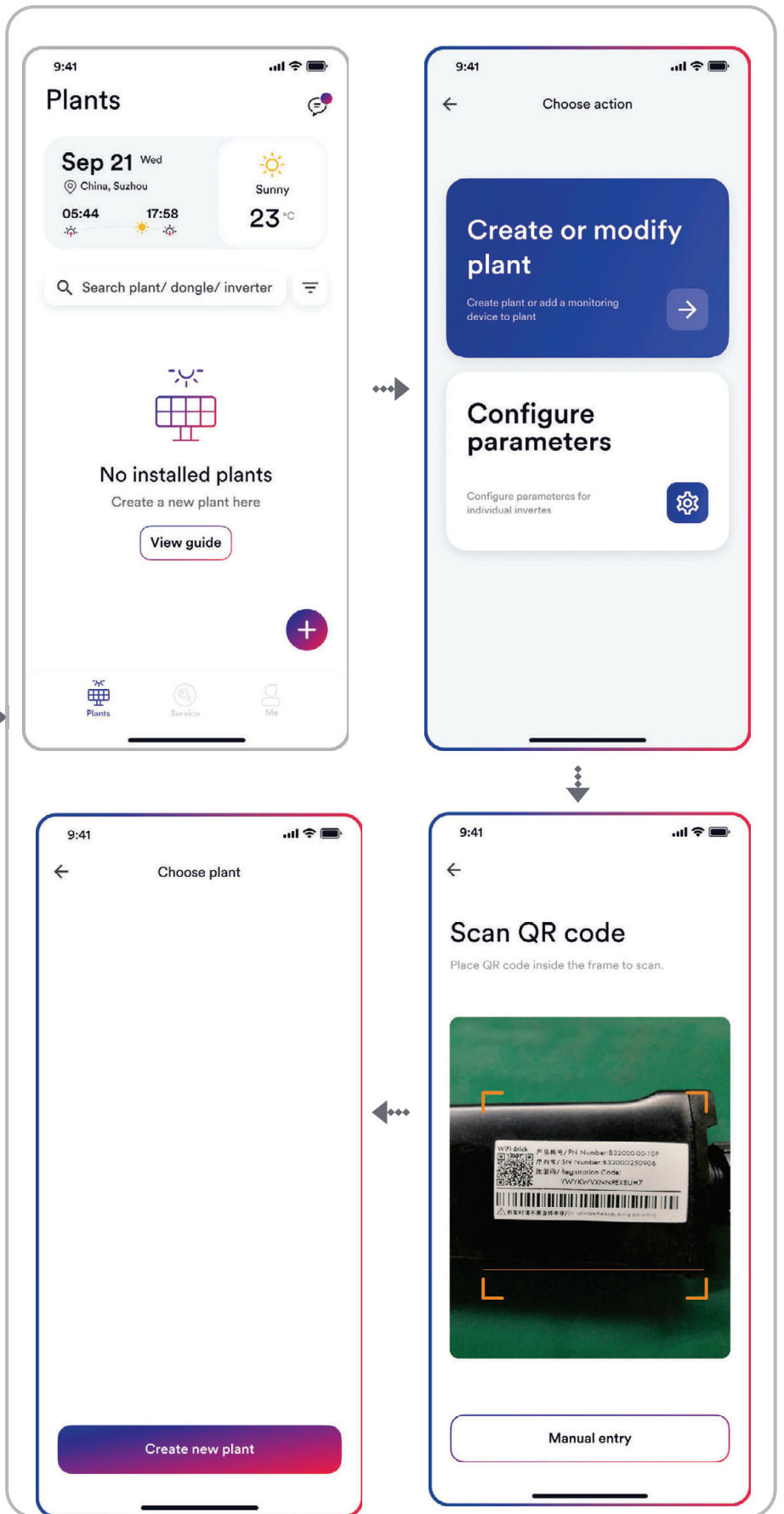

Step 2

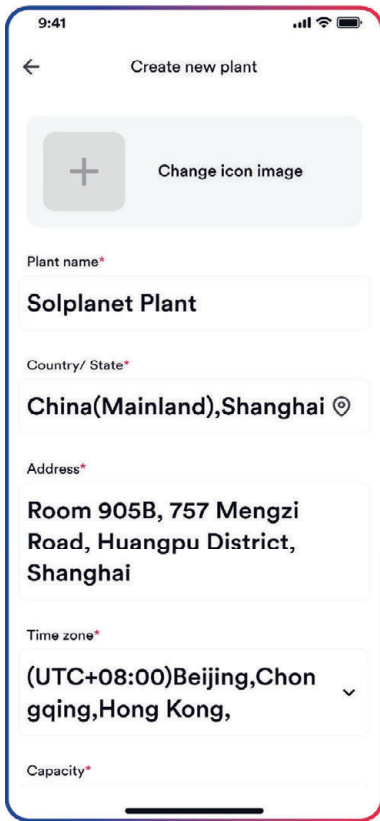

Step 3

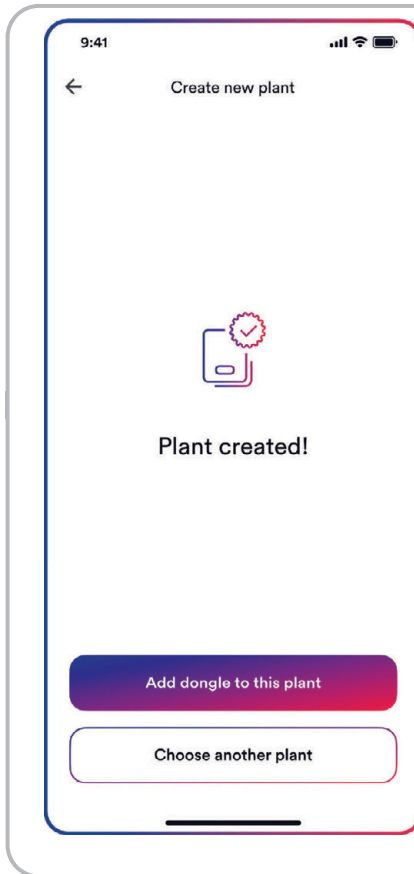

Step 4

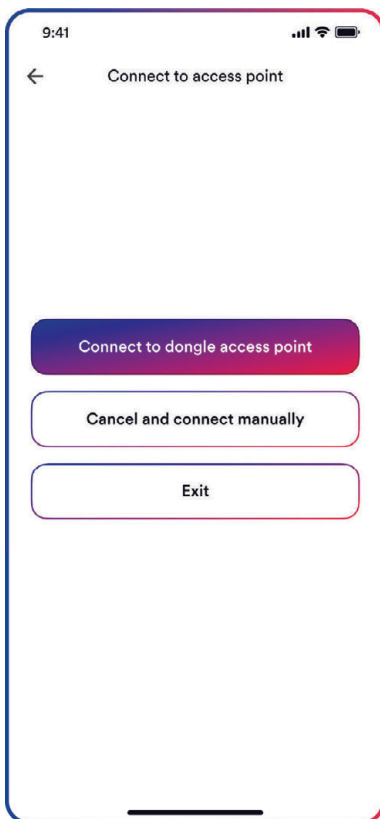
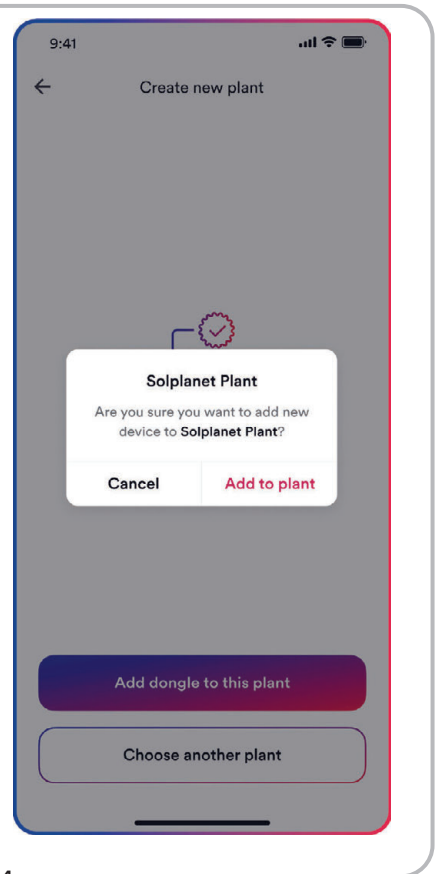

Step 5



Step 6

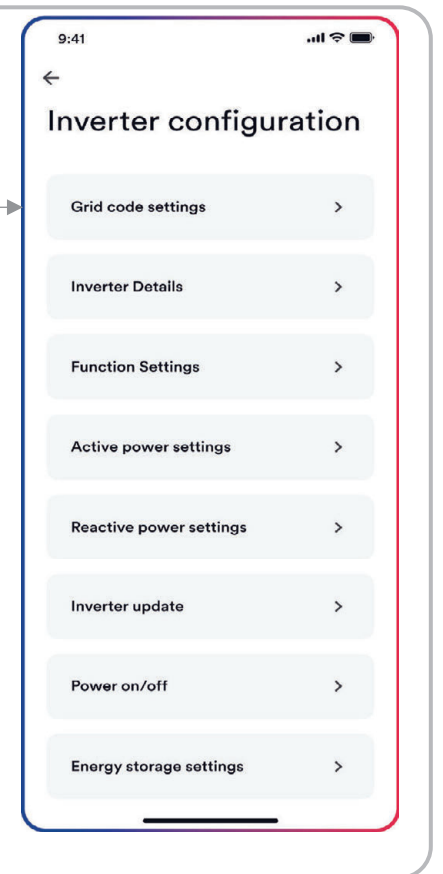



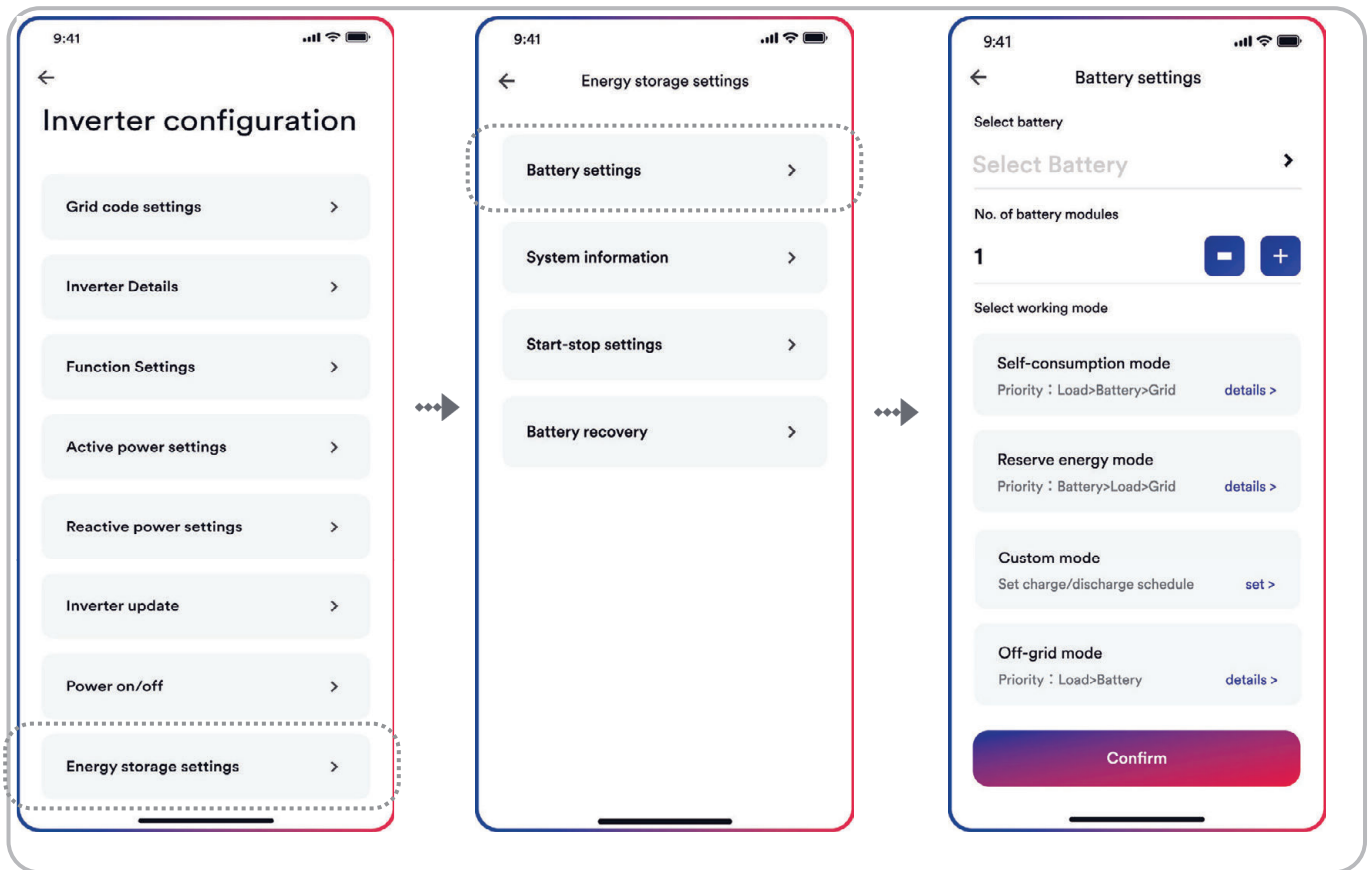

Step 7

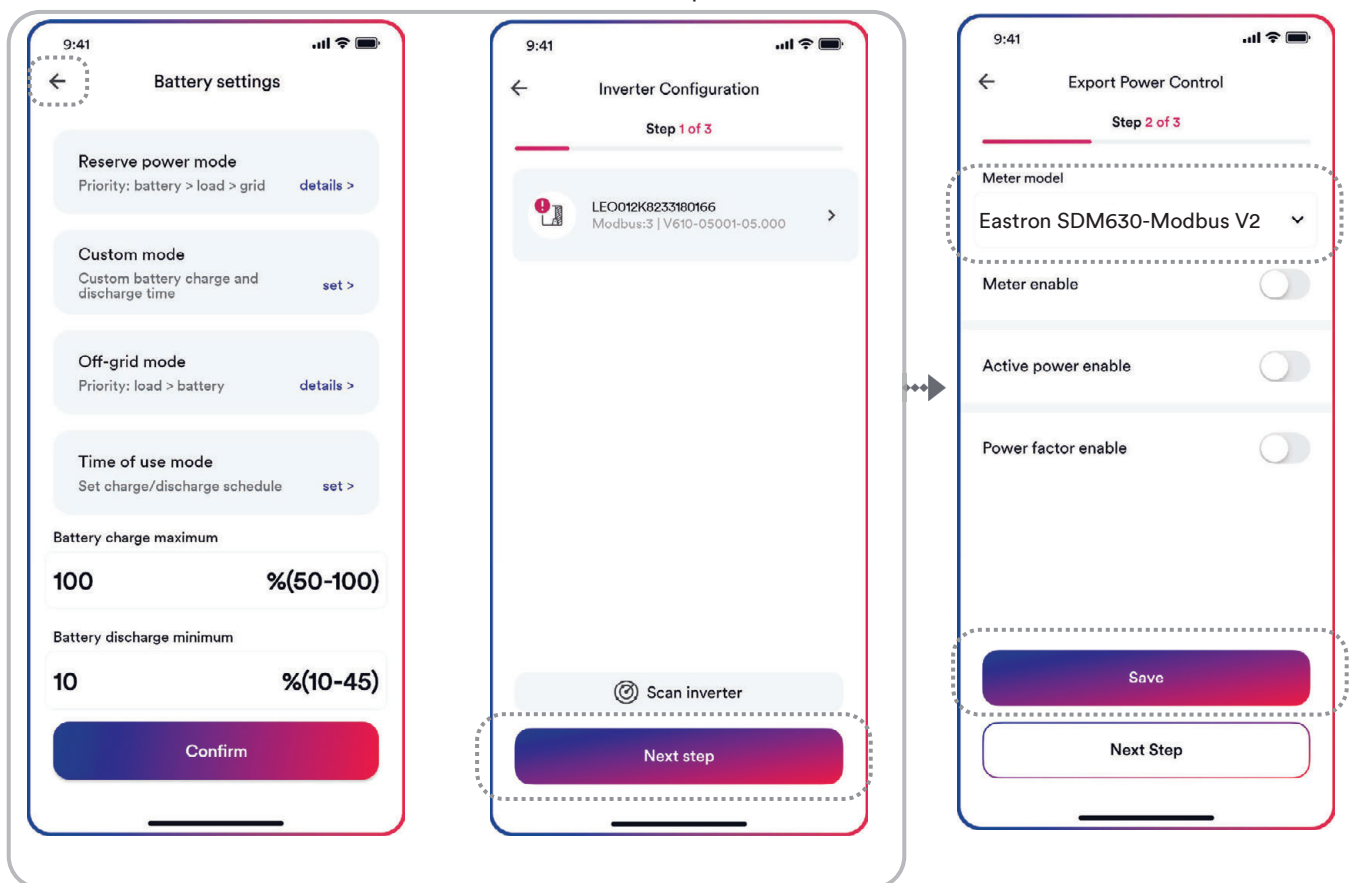

Step 7

Step 8

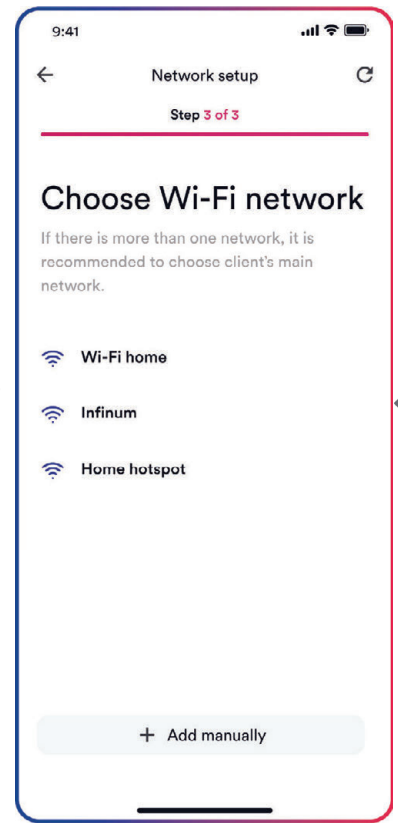
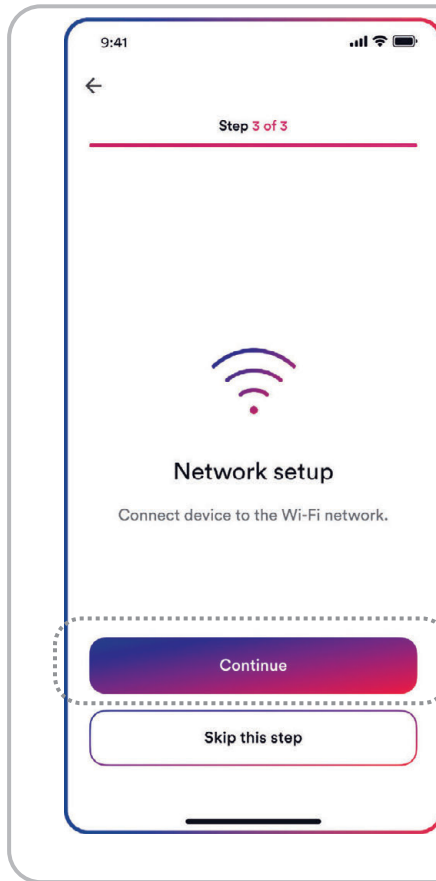
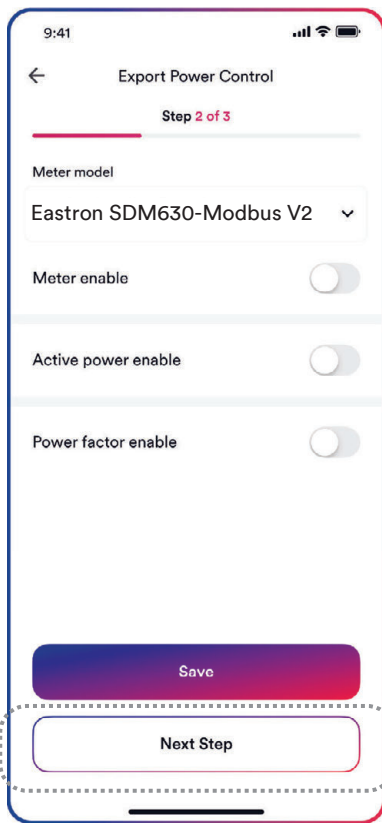

Step 8

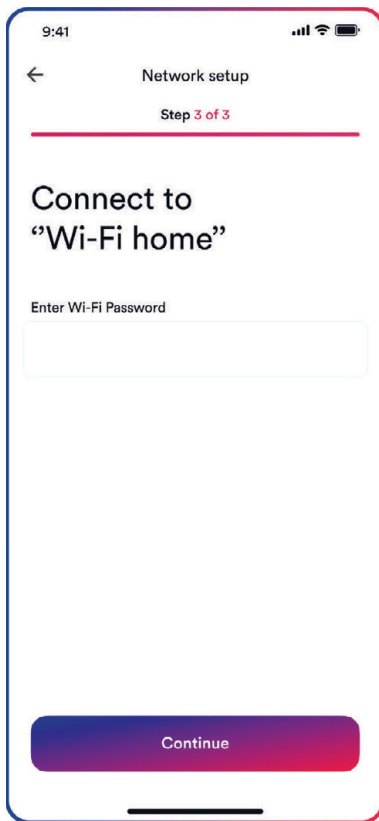

Step 9

Step 9

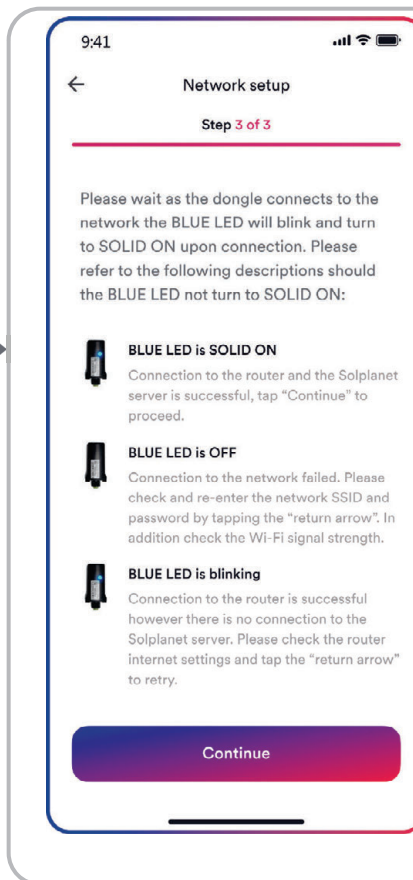

Step 10

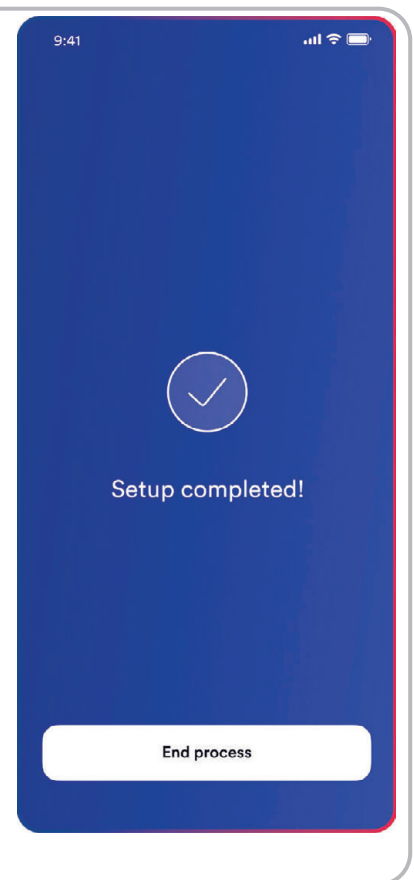

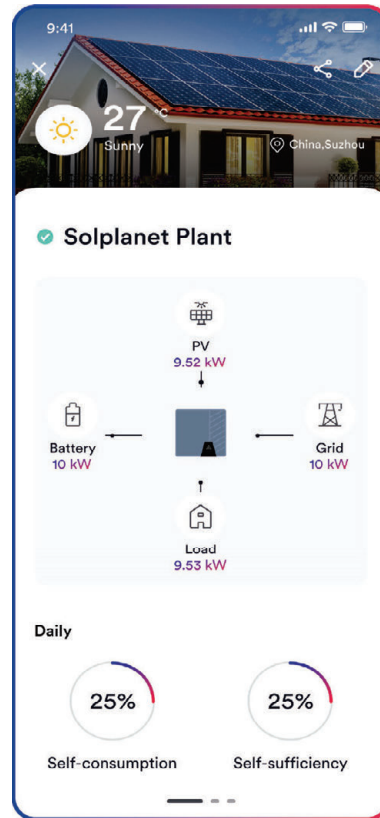
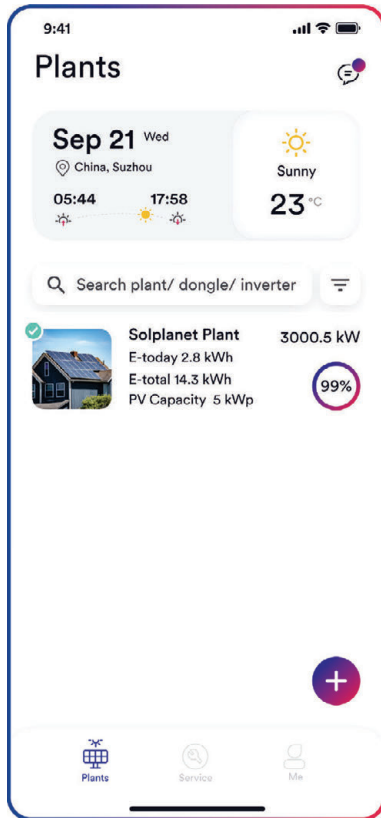

Step 11

## 8.5 Setting parameters

### 8.5.1 Inverter configuration

The Solplanet's products comply with local grid code when leaving the factory. But you still should check the grid code and the parameters according to the requirements of the installation site.

Once configuration of the product is completed, the product will start operating automatically

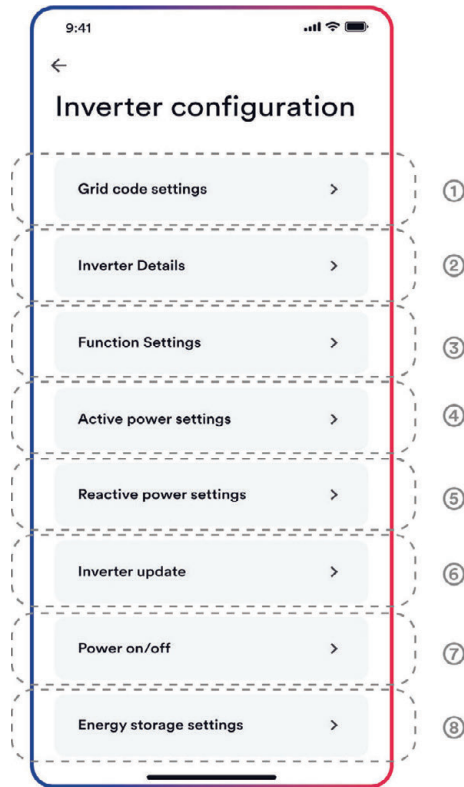

Table description

No.	Function	Description
①	Grid code settings	Choose a safety code. Configure the protection parameters. Configure the start operation parameters and automatic reconnection parameters.
②	Inverter Details	Show the general information of the inverter. Show the present operation value of the inverter.
③	Function settings	Active the general function. Active some special function.
④	Active power settings	Configure the parameters of the P(U) curve. Configure the parameters of the P(f) curve. Configure the parameters of the active power limited. Configure the parameters of the active power increasing and decreasing speed.
⑤	Reactive power settings	Choose the reactive power control mode. Configure the parameters of the Q (U) curve. Configure the parameters of the $\cos \varphi$ (P) curve. Configure the parameters of the fix Q value or fix $\cos \varphi$ value.
⑥	Inverter update	Update the firmware of the inverter and monitor device. Update the safety package.

⑦	Power on/off	Remote turn on/off the inverter on the App.
⑧	Energy storage settings	Configure the parameters of the Hybrid inverter. Configure the parameters of the battery.

### 8.5.2 Grid code settings



For the Australia market, the inverter cannot be connected to the grid before the safety related area is set. Please select from Australia Region A/B/C to comply with AS/NZS 4777.2:2020, and contact your local electricity grid operator on which Region to select.

Normally you only need choose the grid code from the support grid code list. The product has fully complied with the standards that are added in the list. If the local grid operator has the other requirement, you can can set the parameter according to the requirement after you get the approval.

**Procedure:**

**Step 1:** Tap “Grid code setting” to enter to the next page.

**Step 2:** Swipe the smartphone screen to choose the right grid code, then tap “Save” and go back the previous page.

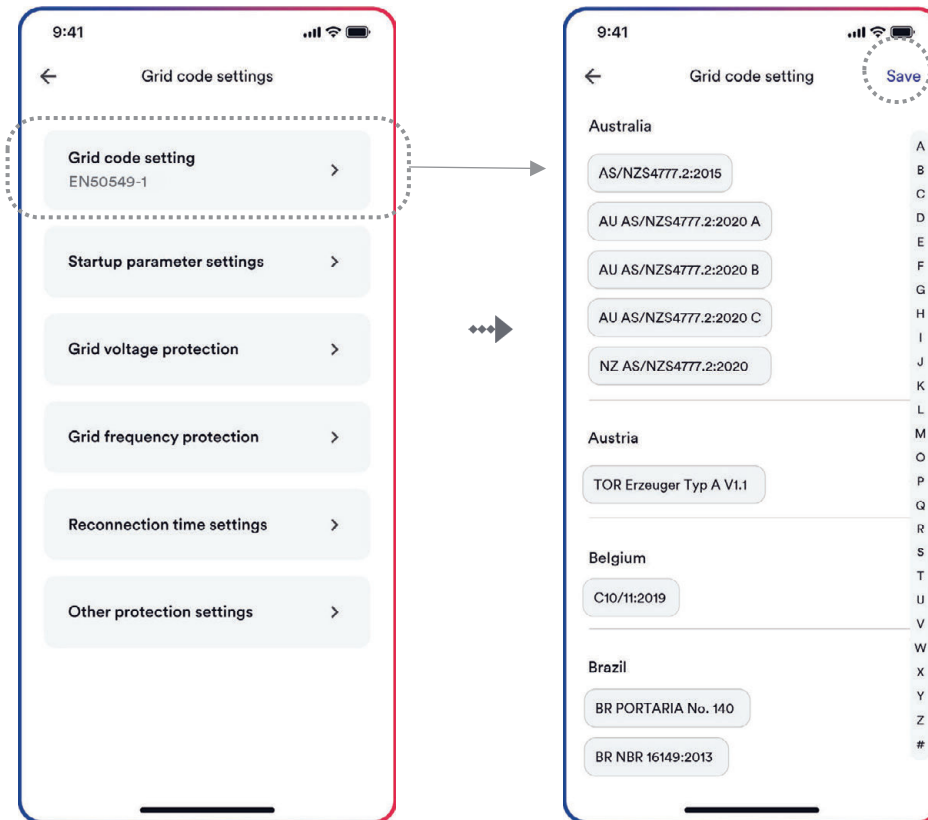

Step 1

Step 2

### 8.5.3 Active power reduction at overfrequency P(f)

There are four modes (Please refer to the following table) can be chosen for this function and many parameters can be configured according to the requirement of the local grid company.

**Procedure:**

- Step 1:** Tap “Active power settings” to enter to the next page.
- Step 2:** Tap “Overfrequency response settings” to enter to the next page.
- Step 3:** Tap the drop-down menu to choose the mode of this function.
- Step 4:** Configure the parameters and tap “Save”.



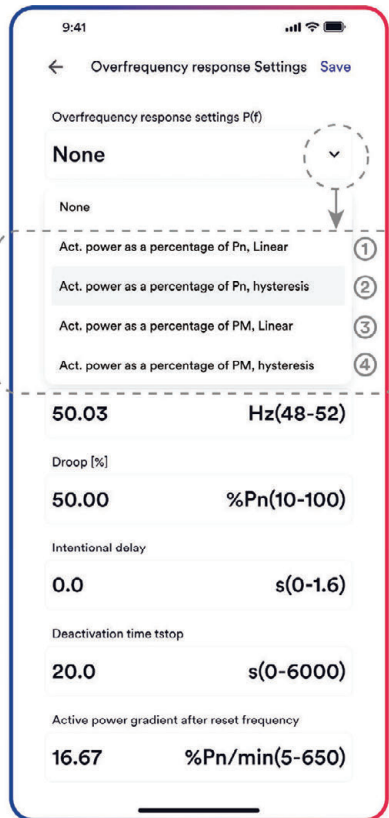

Step 3

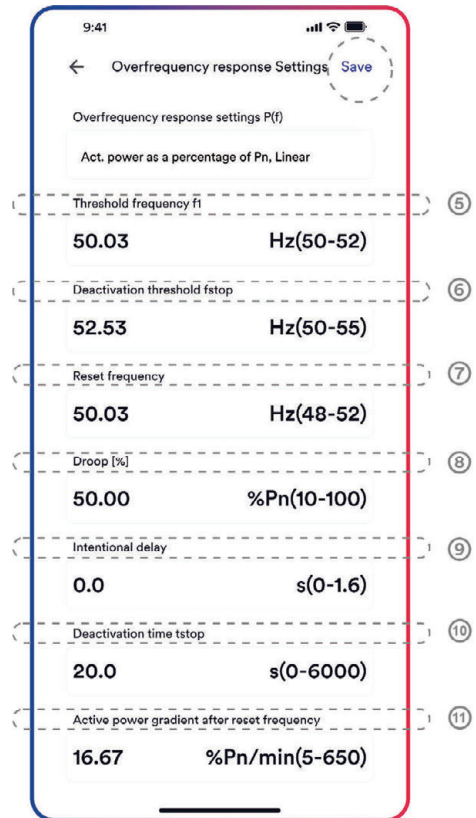

Step 4

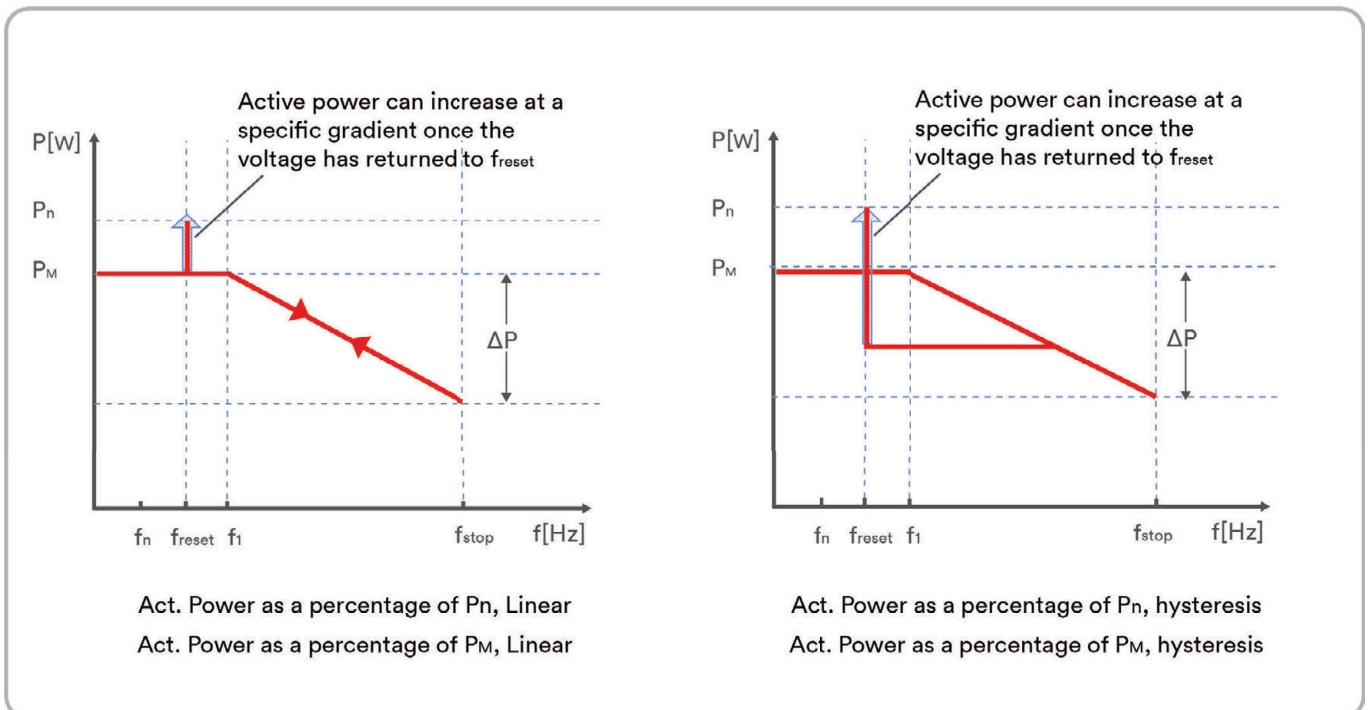

Table description

No.	Name	Description
①	Act. Power as a percentage of $P_n$ , Linear	Droop is defined as the active power as a percentage of $P_n$ . The active power will continuously move up and down the frequency characteristic curve in the frequency range of $f_1$ to $f_{stop}$ .
②	Act. Power as a percentage of $P_n$ , hysteresis	Droop is defined as the active power as a percentage of $P_n$ . The active power shall remain at or below the lowest power output level reached in response to the increase in frequency between $f_1$ to $f_{stop}$ .
③	Act. Power as a percentage of $P_M$ , Linear	Droop is defined as the active power as a percentage of $P_M$ . The active power will continuously move up and down the frequency characteristic curve in the frequency range of $f_1$ to $f_{stop}$ .
④	Act. Power as a percentage of $P_M$ , hysteresis	Droop is defined as the active power as a percentage of $P_M$ . The active power shall remain at or below the lowest power output level reached in response to the increase in frequency between $f_1$ to $f_{stop}$ .
⑤	Threshold frequency $f_1$	The threshold frequency for activating active power response to overfrequency.
⑥	Deactivation threshold $f_{stop}$	The threshold frequency for deactivating the active power response to overfrequency or disconnecting the inverter from the grid.
⑦	Reset frequency $f_{reset}$	The threshold frequency for deactivating the active power response to overfrequency after the frequency reducing.
⑧	Droop $\Delta P$	Reducing the active power in percentage of $P_n$ or $P_M$ when the frequency rise to $f_{stop}$ .
⑨	Intentional delay time	The delay time for activating active power response to overfrequency after the frequency over $f_1$ . An intentional delay shall be programmable to adjust the dead time to a value between the intrinsic dead time and 2s.
⑩	Deactivation time $t_{stop}$	The delay time that the active power can increase after the frequency below $f_{reset}$ .
⑪	Active power gradient	The active power increasing gradient as a percent of $P_n$ per minutes after the frequency reducing to $f_{reset}$ .





Here, the Droop is different from the Droop S in section 3.7.2 of the standard EN 50549-1.

If you want to configure the Droop S, the formula as below should be used to configure.

$$\Delta P = \frac{(f_{\text{stop}} - f_1) / f_n}{\text{Droop S}} \times 100$$

#### 8.5.4 Active power reduction at overvoltage P(U)

There are five modes (Please refer to the following table) can be chosen for this function and many parameters can be configured according to the requirement of the local grid company.

##### Procedure:

- Step 1:** Tap “Active power settings” to enter to the next page.
- Step 2:** Tap “Overfrequency response settings” to enter to the next page.
- Step 3:** Tap the drop-down menu to choose the mode of this function.
- Step 4:** Configure the parameters and tap “Save”.

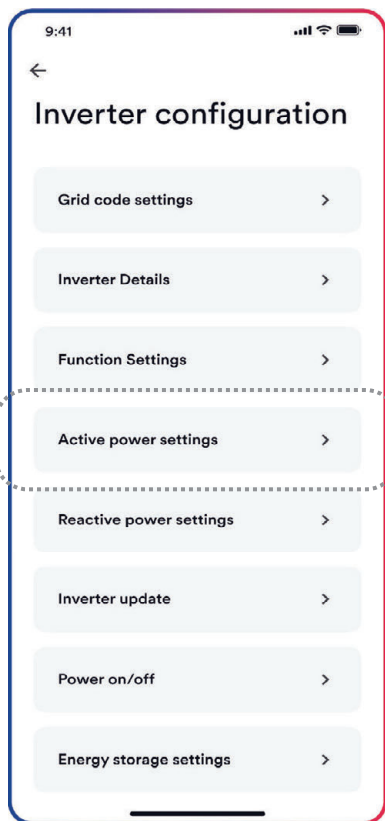

Step 1

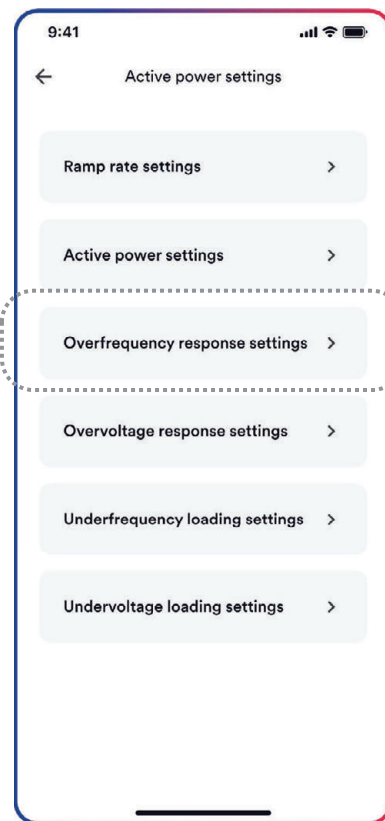

Step 2

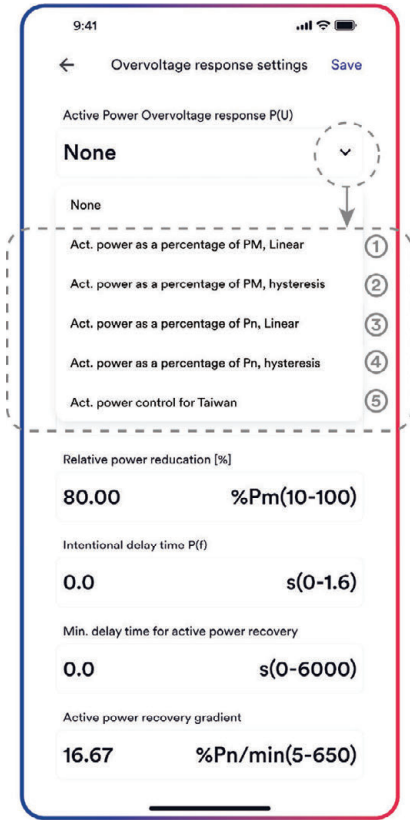

Step 3

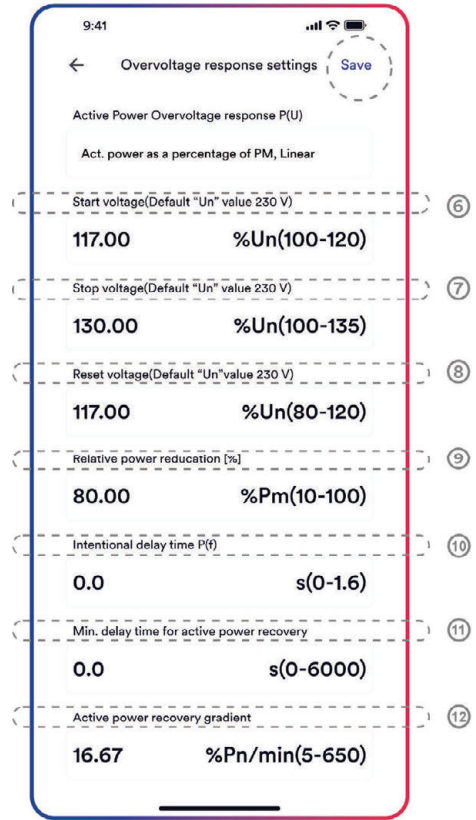

Step 4

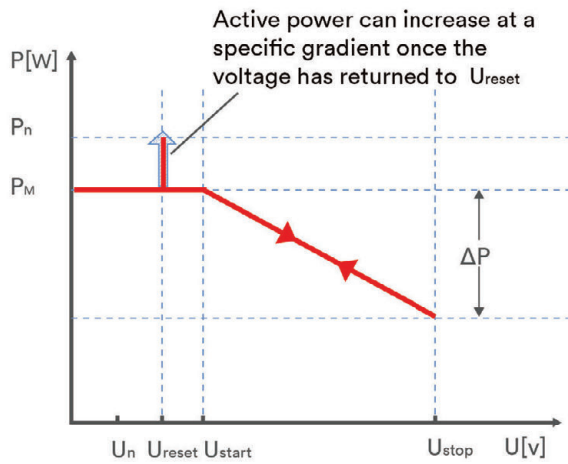

Act. Power as a percentage of  $P_M$ , Linear

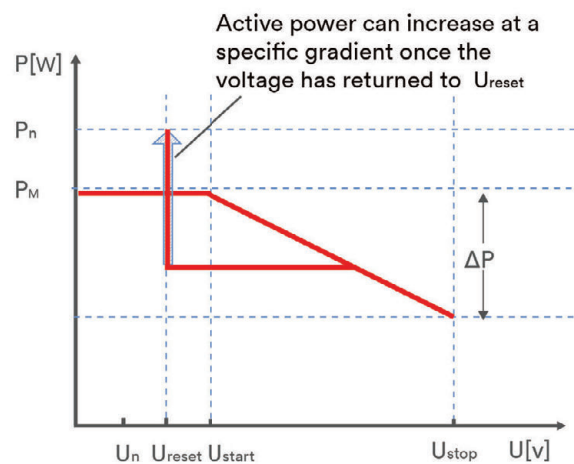

Act. Power as a percentage of  $P_M$ , hysteresis

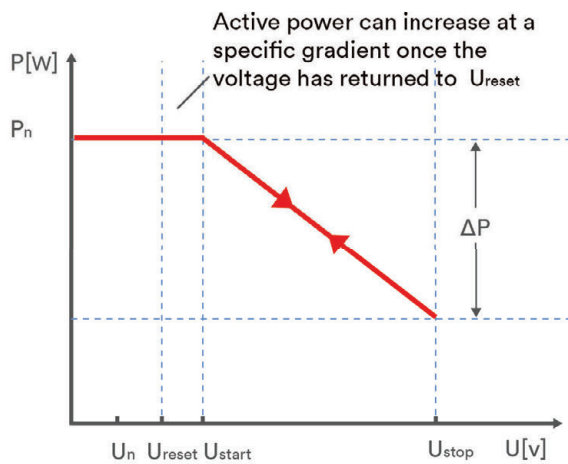

Act. Power as a percentage of  $P_n$ , Linear

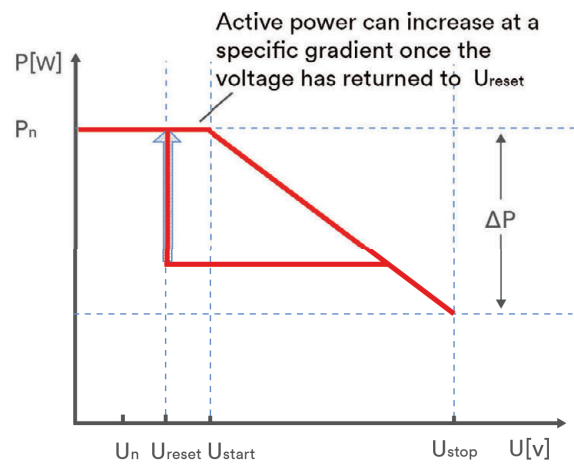

Act. Power as a percentage of  $P_n$ , hysteresis

**Table description**

No.	Name	Description
①	Act. Power as a percentage of $P_M$ , Linear	<p>Droop is defined as the active power as a percentage of <math>P_M</math>.</p> <p>The active power will continuously move up and down the voltage characteristic curve in the voltage range of <math>U_{start}</math> to <math>U_{stop}</math>.</p> <p>The active power reduce from the <math>P_M</math> that is the instantaneous active power at the time of exceeding Start voltage <math>U_{start}</math>.</p>
②	Act. Power as a percentage of $P_M$ , hysteresis	<p>Droop is defined as the active power as a percentage of <math>P_M</math>.</p> <p>The active power shall remain at or below the lowest</p>

		<p>power output level reached in response to the increase in voltage between <math>U_{start}</math> to <math>U_{stop}</math>.</p> <p>The active power reduce from the <math>P_M</math> that is the instantaneous active power at the time of exceeding Start voltage <math>U_{start}</math>.</p>
③	Act. Power as a percentage of $P_N$ , Linear	<p>Droop is defined as the active power as a percentage of <math>P_N</math>.</p> <p>The active power will continuously move up and down the voltage characteristic curve in the voltage range of <math>U_{start}</math> to <math>U_{stop}</math>.</p> <p>The active power reduce from the rated active power <math>P_n</math> at all time. The active power maybe don't reduce if the limited value of the curve is lower than the instantaneous active power at the time of exceeding Start voltage <math>U_{start}</math>.</p>
④	Act. Power as a percentage of $P_N$ , hysteresis	<p>Droop is defined as the active power as a percentage of <math>P_N</math>.</p> <p>The active power shall remain at or below the lowest power output level reached in response to the increase in the voltage range of <math>U_{start}</math> to <math>U_{stop}</math>.</p> <p>The active power reduce from the rated active power <math>P_n</math> at all time. The active power maybe don't reduce if the limited value of the curve is lower than the instantaneous active power at the time of exceeding Start voltage <math>U_{start}</math>.</p>
⑤	Act. Power control for Taiwan	Special control mode for Chinese Taiwan market.
⑥	Start voltage $U_{start}$	The threshold voltage for activating active power response to overvoltage.
⑦	Stop voltage $U_{stop}$	The threshold voltage for deactivating the active power response to overvoltage or disconnecting the inverter from the grid.
⑧	Reset voltage $U_{reset}$	<p>The threshold voltage for deactivating the active power response to overvoltage after the voltage reducing.</p> <p>Reset voltage does not work in the mode "Act. Power as a percentage of <math>P_N</math>, Linear".</p>
⑨	Droop $\Delta P$	Reducing the active power in percentage of $P_N$ or $P_M$ when the voltage rise to $U_{stop}$ .
⑩	Intentional delay time	The delay time for activating active power response to overvoltage after the voltage over $U_{start}$ . An intentional delay shall be programmable to adjust the dead time to a value between the intrinsic dead time and 2s.
⑪	Deactivation time $t_{stop}$	The delay time that the active power can increase after the voltage below $U_{reset}$ .
⑫	Active power gradient	The active power increasing gradient as a percent of $P_n$ per minutes after the frequency reducing to $f_{reset}$ .

## 8.5.5 $\cos\phi(P)$ curve configuration

The power related control mode  $\cos\phi(P)$  controls the  $\cos\phi$  of the output as a function of the active power output.

There are four coordinate points that can be configured. The coordinate points are the active power as a percentage of  $P_n$  and the displacement factor  $\cos\phi$ .

### Procedure:

**Step 1:** Tap “Reactive power settings” to enter to the next page.

**Step 2:** Tap “Enable reactive power” to choose the reactive power control mode and tap the left arrow to go back.

**Step 3:** Tap “ $\cos\phi(P)$  curve settings” to enter to the next page.

**Step 4:** Configure the parameters and tap “Save”.

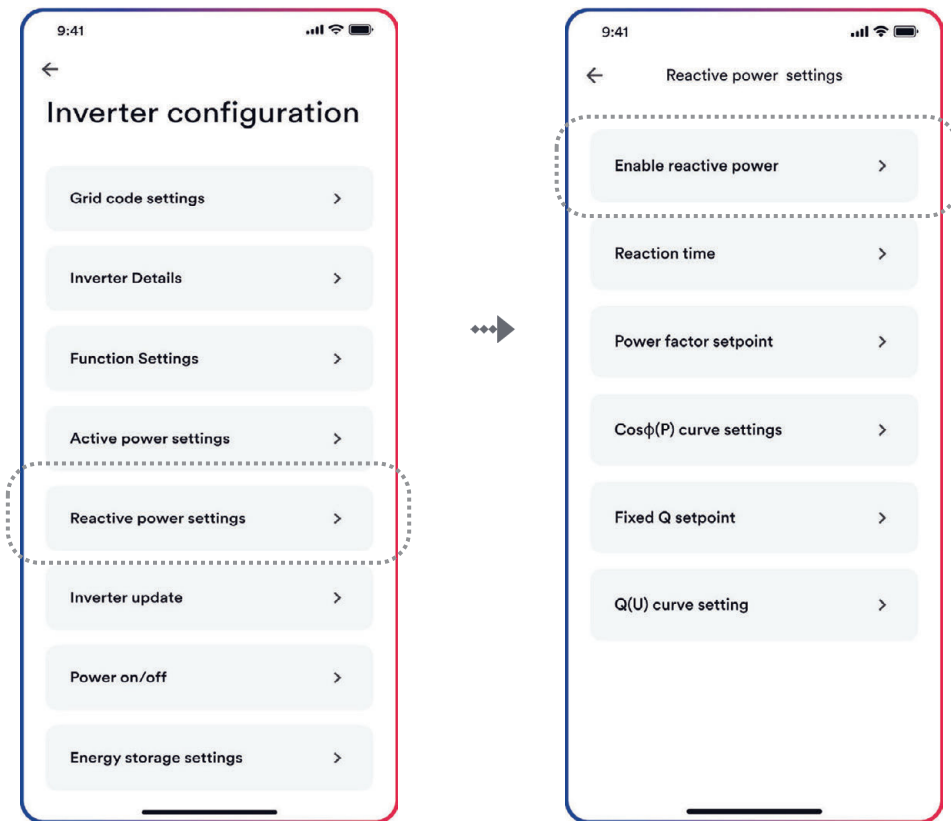

Step 1

Step 2

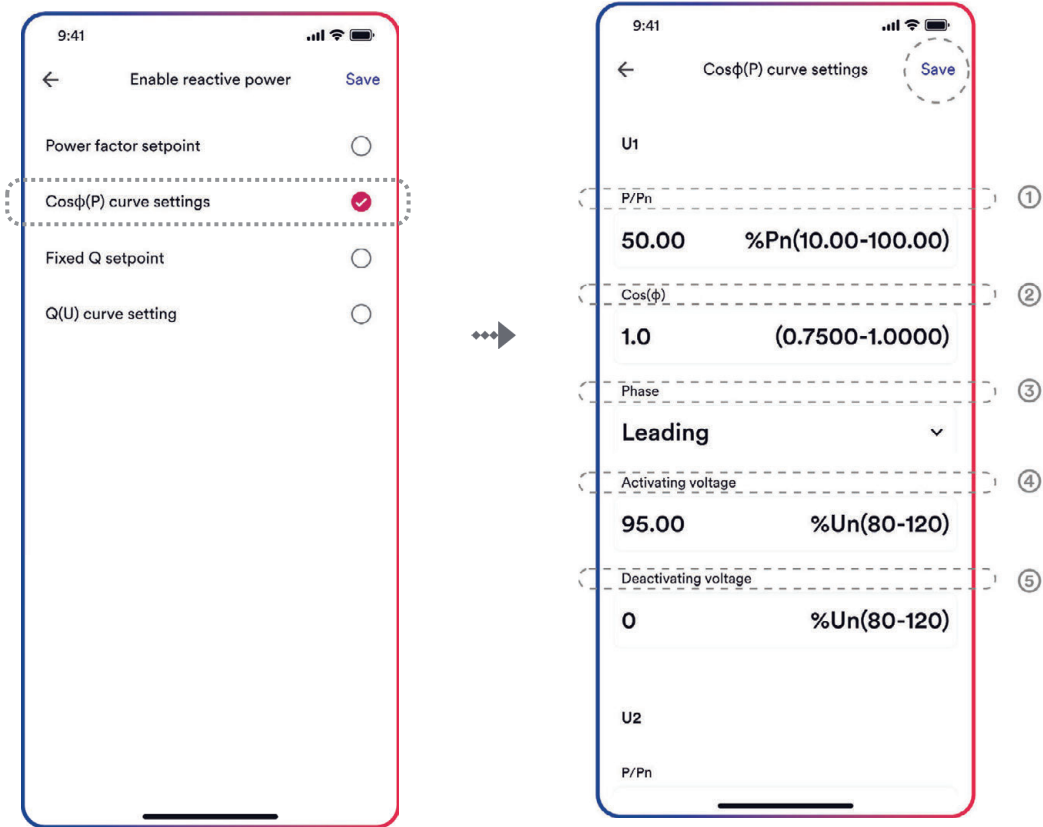

Step 3

Step 4

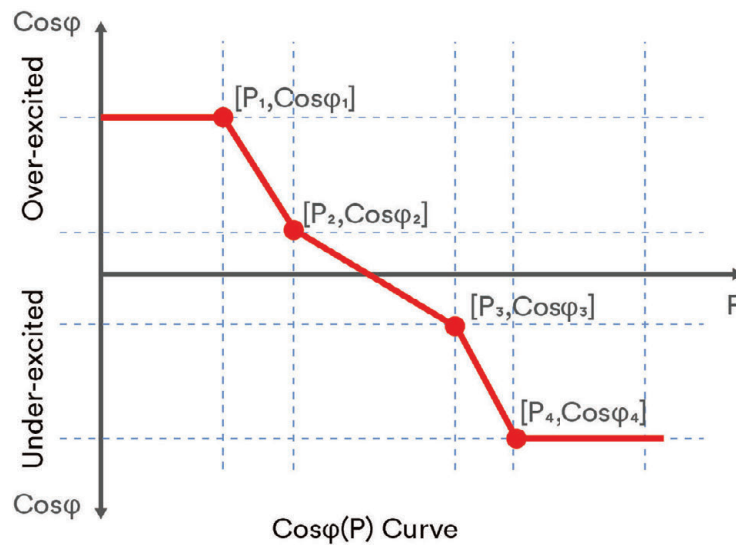

**Table description**

No.	Parameter	Description
①	P/P <sub>n</sub>	The active power as a percentage of P <sub>N</sub> .
②	Cosφ	The displacement factor that is cosine of the phase angle between the fundamental components of the line to neutral point voltage and the respective current.
③	Phase	Choose the over-excited or under-excited.

④	Activating voltage	The lock-in voltage value that enables the automatic reactive power delivery mode. Activation threshold as a percentage of $U_n$ corresponds to 'lock-in' voltage.
⑤	Deactivating voltage	The lock-out voltage value that disables the automatic reactive power delivery mode. Deactivation threshold as a percentage of $U_n$ corresponds to 'lock-out' voltage.



Some grid companies maybe requires two voltage thresholds as a percentage of  $U_n$  to activate or deactivate the function. The voltage thresholds normally call 'lock-in' and 'lock-out' voltage.

### 8.5.6 Q(U) curve configuration

The voltage related control mode Q(U) controls the reactive power output as a function of the voltage.

There are four coordinate points that can be configured. The coordinate points are the voltage as a percentage of  $U_n$  and the reactive power as a percentage of  $P_n$ .

#### Procedure:

**Step 1:** Tap "Reactive power settings" to enter to the next page.

**Step 2:** Tap "Enable reactive power" to choose the reactive power control mode and tap the left arrow to go back.

**Step 3:** Tap "Q(U) curve settings" to enter to the next page.

**Step 4:** Configure the parameters and tap "Save".

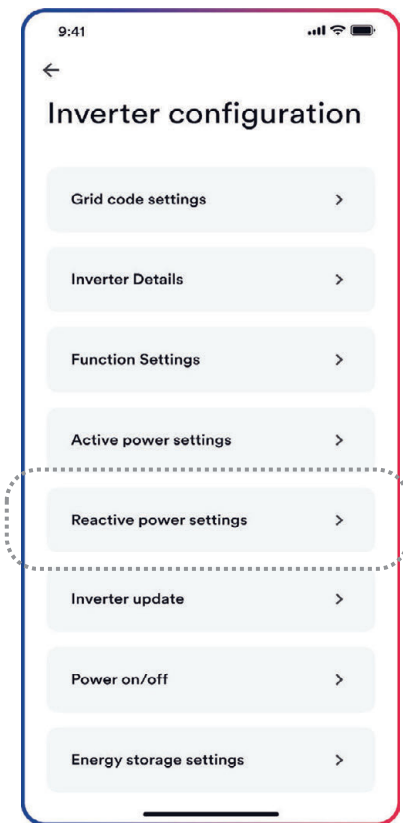

Step 1

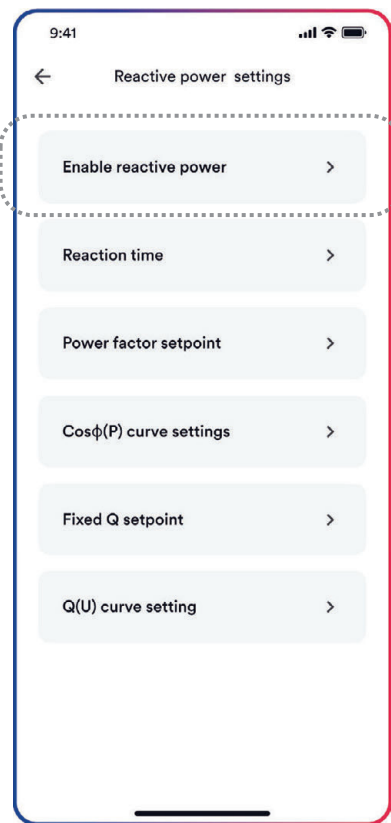

Step 2

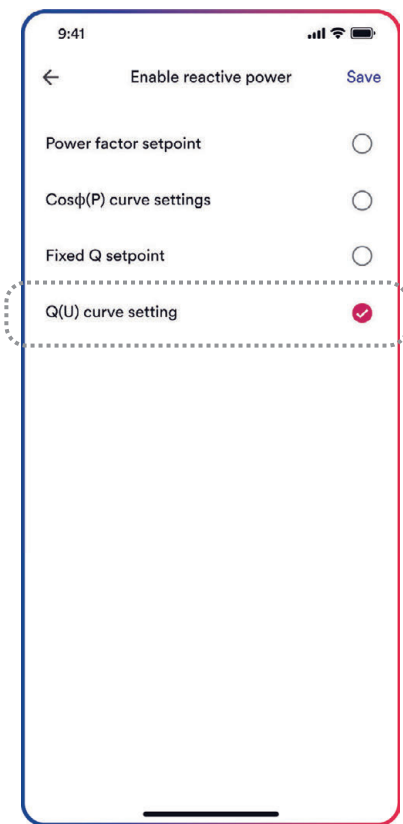

Step 3

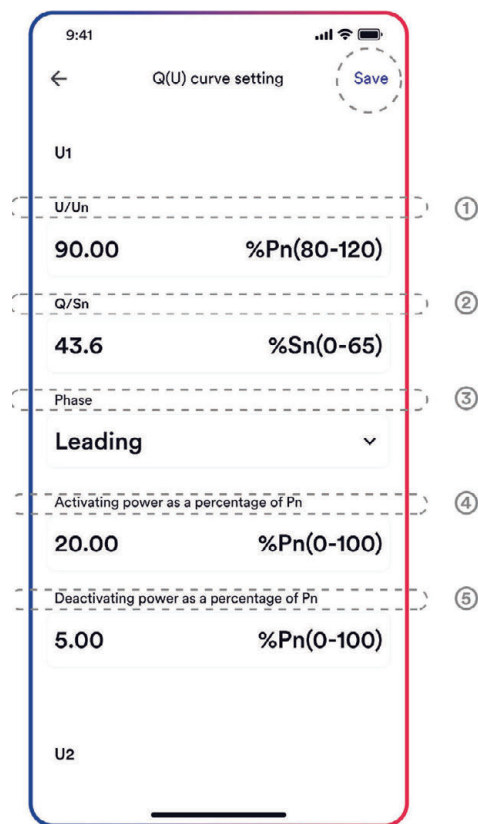

Step 4



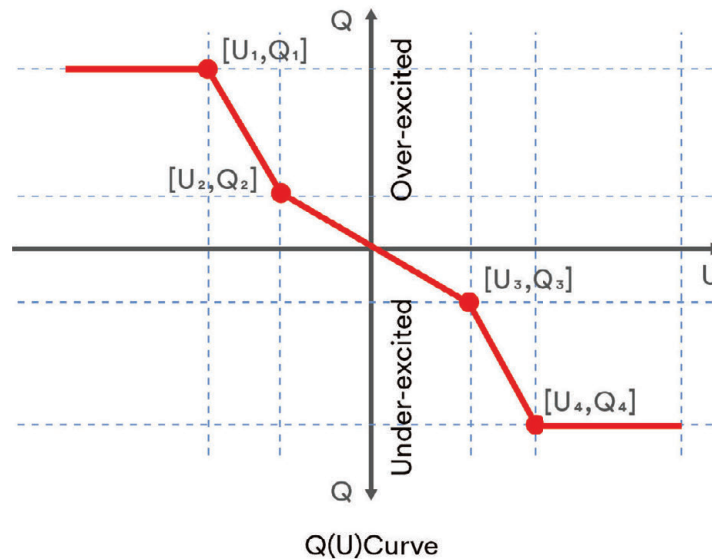

**Table description**

No.	Name	Description
①	$U/U_n$	The voltage as a percentage of $U_n$ .
②	$Q/P_n$	The reactive power as a percentage of $P_n$ .
③	Phase	Choose the over-excited or under-excited.
④	Activating power as a percentage of $P_n$	The lock-in active power value that enables the automatic reactive power delivery mode. Activation threshold as a percentage of $P_n$ corresponds to 'lock-in' power.
⑤	Deactivating power as a percentage of $P_n$	The lock-out active power value that disables the automatic reactive power delivery mode. Deactivation threshold as a percentage of $P_n$ corresponds to 'lock-out' power.



Some grid companies maybe requires two active power thresholds as a percentage of  $P_n$  to activate or deactivate the function. The active power thresholds normally call 'lock-in' and 'lock-out' active power.

## 8.6 Parallel parameter setting and using

The product is shipped based to the single inverter configuration. Parallel application requires reset the parameters. After the parallel system assembly is completed, the steps for setting parameters are as follows:

**Step 1:** Refer to Chapters 8.1-8.5 to download and install the APP, configure the power station, and connect to the Internet.

**Step 2:** Tap "Create or modify a plant", then the camera of the mobile automatically turns on, and scan the QR code of the Ai-dongle to enter the next screen, tap "Create new plant" to the next screen.

**Step 3:** Tap “Scan inverter”, the serial numbers of all inverters in the parallel system will be scanned out, and the APP will automatically set the inverter with stick as the master inverter, and the other inverters as slave inverter. If any are missing, confirm the wiring and scan again.

**Step 4:** Tap “Configure parameters”, then the camera of the mobile automatically turns on, and scan the QR code of the the Ai-dongle to enter the next screen, choose the inveter setting parameters.



- Power on the PV of all parallel inverters, but do not power on the battery and AC.
- When the parallel wiring is completed, the battery and AC power cannot be connected before the parallel parameters are setup. Unless remote shutdown is set for each inverter through the APP, the master inverter can be turned on again after setting up the parallel system.

For parallel system, all inverters are setup through the master inverter page.

After setting the master inverter parameters, all slaver inverters will set this parameter. For example, if master inverter set the output power to 1KW in a system with four inverters, the output power of the entire system is 1KW\*4.

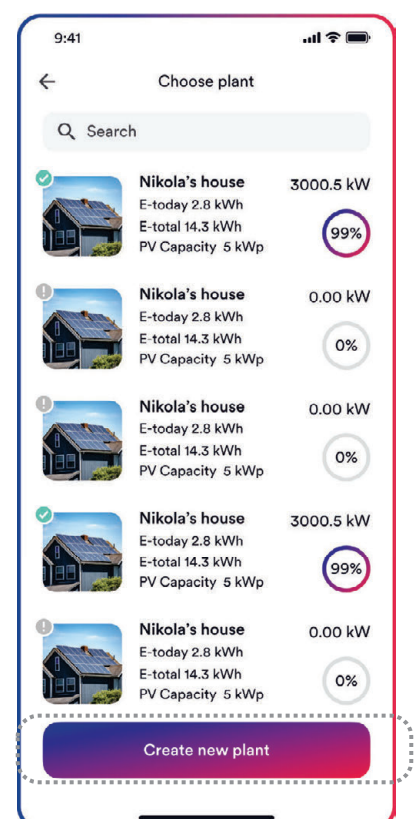

Step 2

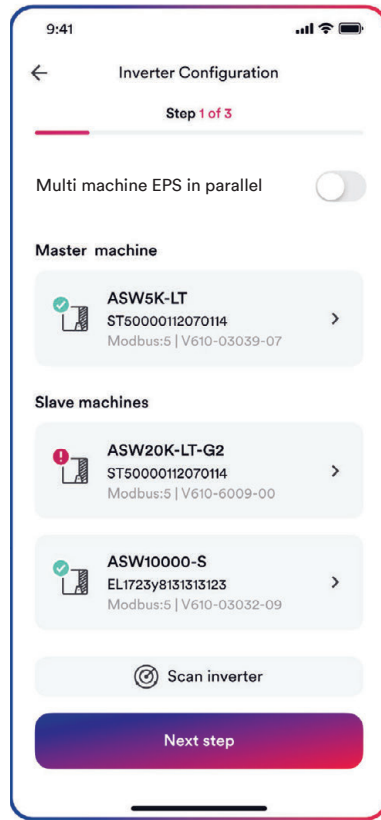
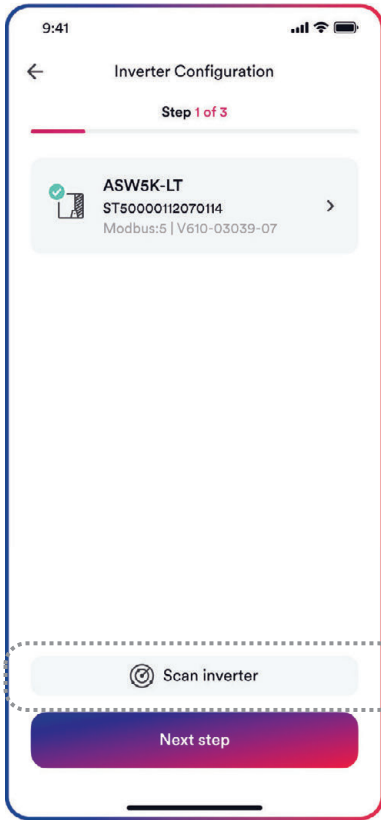

Step 3

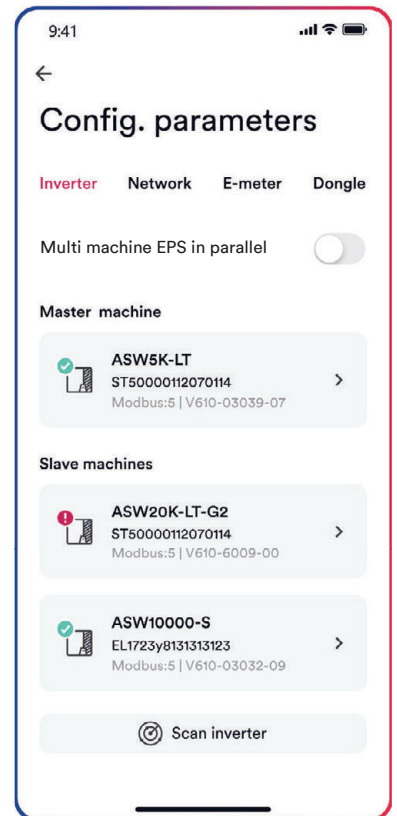

Step 4

## 8.7 Split phase control

If user enable **Split phase control enable**, the inverter will asynchronous output. Which means that in self-consumption mode with unbalance three phase load, the inverter correspondingly output three-phase imbalance unless load power is too high (above 1/3 rate power) to consume grid power. Besides, if 0 export control is setup in this condition, each phase will do not feed in power to grid.

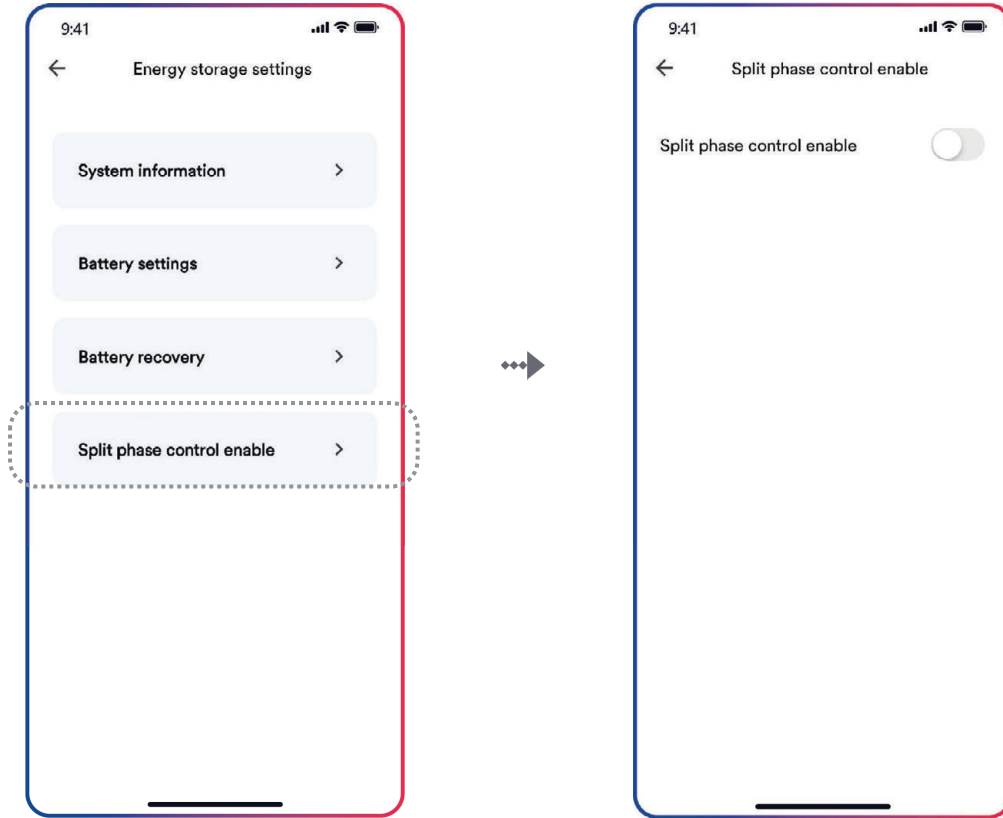

Before enable **Split phase control**, make sure the phase sequence of CT or meter is consistent with grid and inverter. otherwise inverter will work abnormal.

## 8.8 Activated Arc-fault Circuit Interrupter (AFCI)

The Solplanet App can establish a communication connection to the inverter via WLAN, thereby achieving near-end maintenance on the inverter. The Arc-fault Circuit Interrupter (AFCI) function can be activated on the Solplanet App.

Both the "Business user" and "End user" user groups can activate the AFCI function during PV plant commissioning. However, only the "Business user" can activate the AFCI function after the PV plant is operating normally.

### Procedure:

- Step 1:** Refer to "8.4 Create a plant" to enter the "Inverter Configuration" screen.
- Step 2:** Tap "Function Settings" to enter the next screen, and tap "AFCI" to enter the next screen.
- Step 3:** Tap the switch "Enable AFCI", then the automatic self-test function will be performed.

**Step 4:** The “Alarm detection sensitivity” and “Reconnection method” can be chosen. If "Low sensitivity" is chosen, the inverter will automatically analyze and determine whether the current fault is a genuine arc fault, and the error code will be sent only for genuine arc faults. If "Normal sensitivity" is chosen, the error code will be sent immediately.



When the AFCI function is enabled for the first time, a self-test will be performed automatically before operation. Additionally, the self-test will be performed once every 24 hours after the initial operation. If manual reconnection is chosen, the inverter will not restart after detecting an arc until the fault is cleared manually. If automatic reconnection is chosen, the inverter will restart with a minimum delay time of 5 minutes after detecting an arc. When interrupting the fifth time within a 24 h period, the inverter is only allowed to be reset manually.

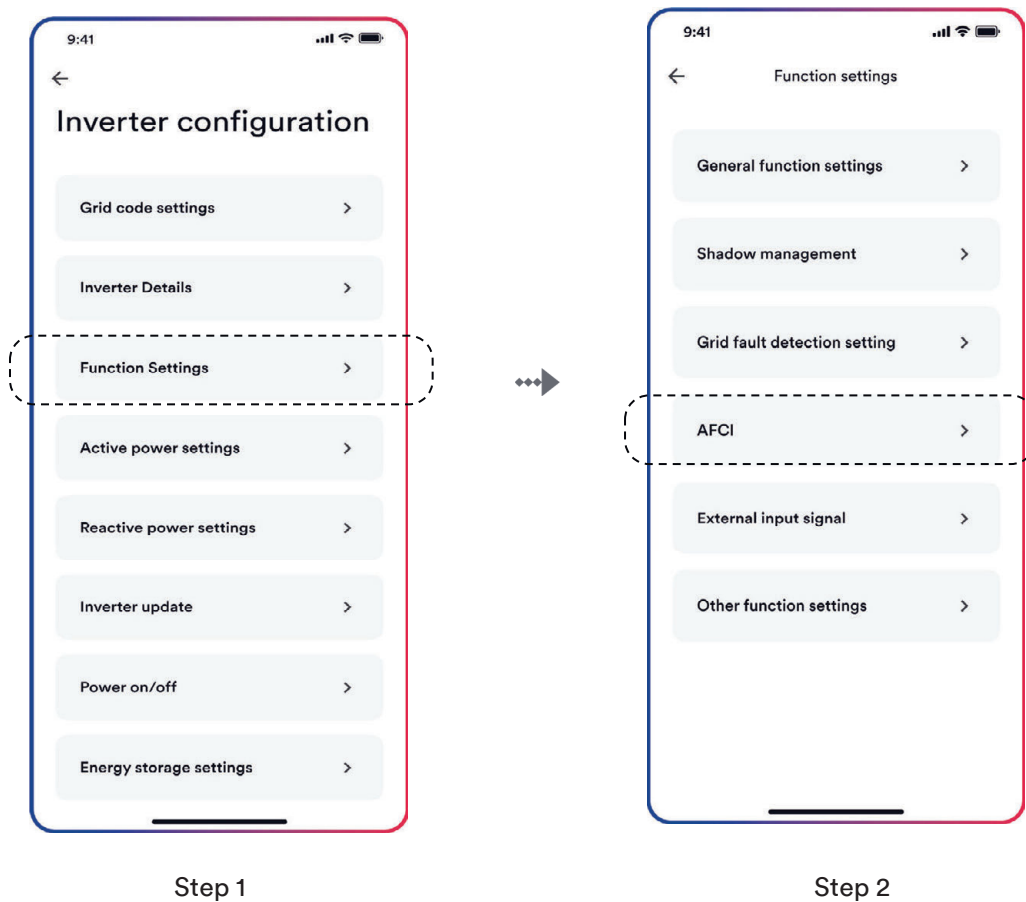

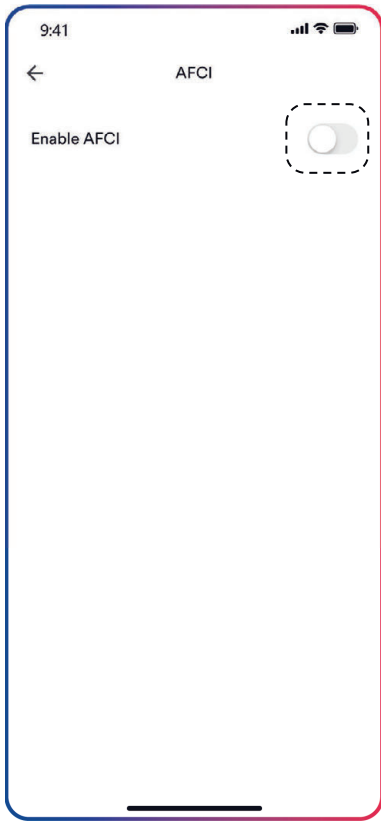

Step 3

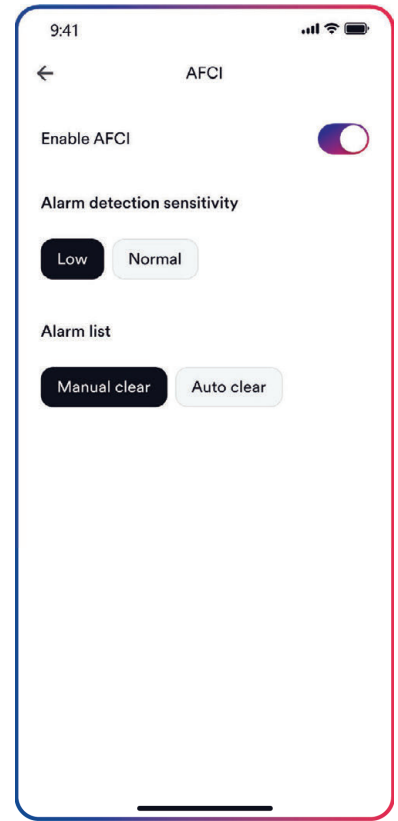
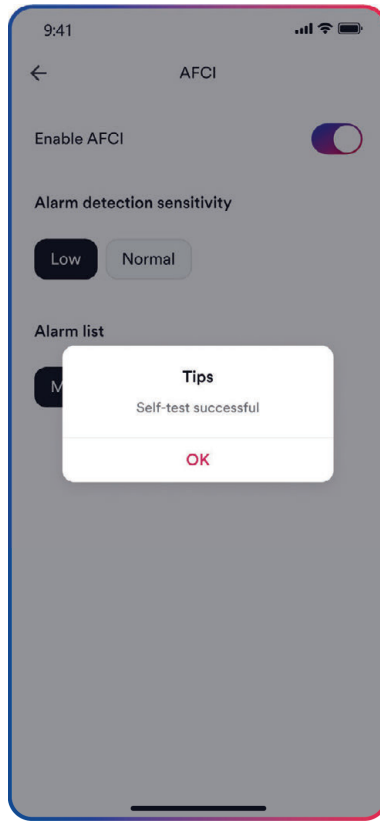

Step 4

## 9 Decommissioning the product

### 9.1 Disconnecting the inverter from voltage sources

Prior to performing any work on the product, always disconnect it from all voltage sources as described in this section. Always adhere to the prescribed sequence.

#### **WARNING**

Danger to life due to electric shock from destruction of the measuring device due to overvoltage!

Overvoltage can damage a measuring device and result in voltage being present in the enclosure of the measuring device. Touching the live enclosure of the measuring device results in death or lethal injuries due to electric shock.

Only use measuring devices with a DC input voltage range of 1100 V or higher.

#### **Procedure:**

**Step 1:** Disconnect the miniature circuit breaker and secure against reconnection.

**Step 2:** Disconnect the DC switch and secure against reconnection.

**Step 3:** Wait until the LEDs have gone out.

**Step 4:** Use a current clamp meter to ensure that no current is present in the DC cables.

#### **DANGER**

Danger to life due to electric shock when touching exposed DC conductors or DC plug contacts if the DC connectors are damaged or loose!

The DC connectors can break or become damaged, become free of the DC cables, or no longer be connected correctly if the DC connectors are released and disconnected incorrectly. This can result in the DC conductors or DC plug contacts being exposed. Touching live DC conductors or DC plug connectors will result in death or serious injury due to electric shock.

Wear insulated gloves and use insulated tools when working on the DC connectors.

Ensure that the DC connectors are in perfect condition and that none of the DC conductors or DC plug contacts are exposed.

Carefully release and remove the DC connectors as described in the following.

**Step 5:** Loosen and remove the DC connector.

#### Type 1 DC connector

Release and remove the DC connectors. To do so, insert a flat-blade screwdriver or an angled screwdriver (blade width: 3.5mm) into one of the side slots and pull the DC connectors out.

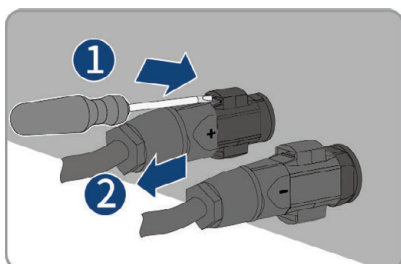

#### Type 2 DC connector

To remove DC plug connectors, insert a wrench tool into the slots and press the wrench tool with an appropriate force.

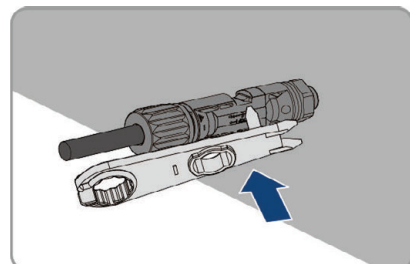

**Step 6:** Ensure that no voltage is present between the positive terminal and negative terminal at the DC inputs using a suitable measuring device.

**Step 7:** Loosen and remove the Grid connector.

#### Unlock instructions

① Rotate the latch as shown.

② Remove the female end of the cable to unlock the account.

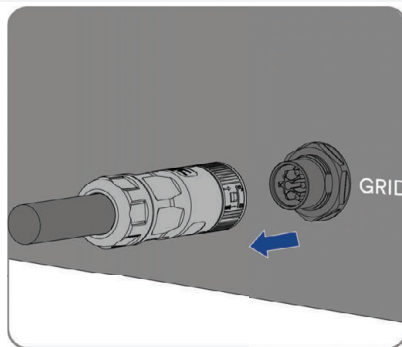
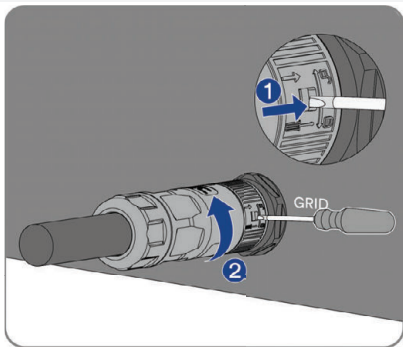

**Step 8:** Loosen and remove the EPS Load connector.

#### Unlock instructions

① Rotate the latch as shown.

② Remove the female end of the cable to unlock the account.

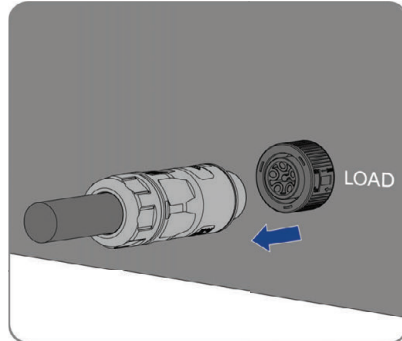
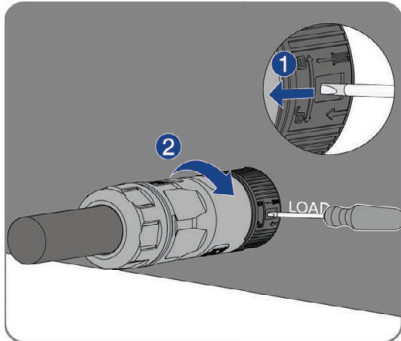

**Step 9:** Loosen and remove the Battery connector.

#### Unlock instructions

① Insert a flat-blade screwdriver or an angled screwdriver (blade width: 3.5mm) into one of the side slots.

② Pull the DC connectors out.

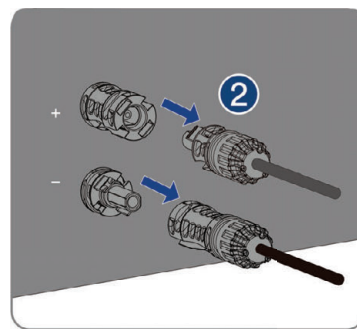
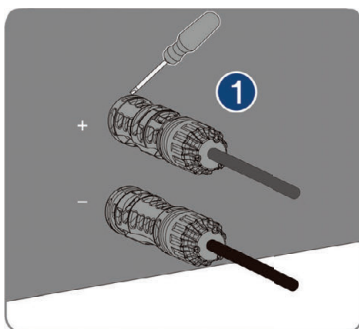



**Step 10:** Remove the communication cover. Remove the communication cable in reverse order by referring to 6.7 Communication equipment connection.

**Step 11:** Hold down the buckle on the side of the Ai-Dongle and pull out the Ai-Dongle terminal.

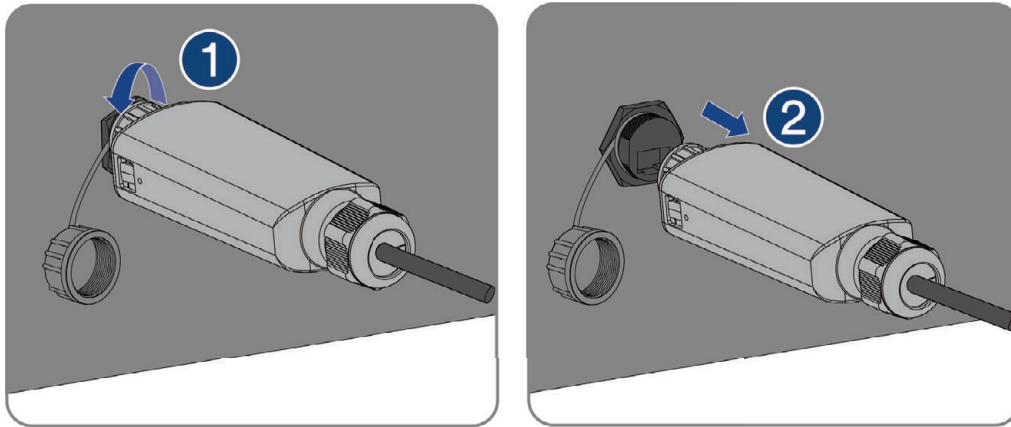

## 9.2 Dismantling the inverter

After disconnecting all electrical connections as described in Section 9.1, the inverter can be removed as follows

### Procedure:

**Step 1:** Dismantle the inverter referring to “5.3 Mounting” in reverse steps.

**Step 2:** If necessary, remove the wall-mounting bracket from the wall.

**Step 3:** If the inverter will be reinstalled in the future, please refer to “3.2 Inverter Storage” for a proper conservation.

## 10 Technical data

### 10.1 ASW05kH/06kH/08kH/10kH/12kH-T2

#### 10.1.1 For European market

Type	ASW05kH -T2	ASW06kH -T2	ASW08kH -T2	ASW10kH -T2	ASW12kH -T2
<b>DC Input</b>					
Maximum power of PV array	7500 Wp	9000 Wp	12000 Wp	15000 Wp	18000 Wp
Max. power per MPP tracker	7500 W	9000 W	10000 W	10000 W	10000 W
Maximum input voltage	1100 V				
Rated input voltage	630 V				
Minimum input voltage	60 V				
Start voltage	180 V				
MPP voltage range	150-950 V	150-950 V	200-950 V	200-950 V	200-950 V
MPP voltage range at Pnom	250~850 V	290~850 V	350-850 V	380-850 V	450-850 V
Max. input current	20 A/20 A				
Isc PV (absolute maximum)	30 A/30 A				
Maximum reverse current into the PV modules	0 A				
Number of independent MPP inputs	2				
Strings per MPP input	PV1:1/PV2:1				
Overvoltage category in accordance with ICE 60664-1	II				
<b>AC Input and Output</b>					
Rated output power at 230 V	5000 W	6000 W	8000 W	10000 W	12000 W
Rated apparent power at $\cos\varphi = 1$	5000 VA	6000 VA	8000 VA	10000 VA	12000 VA
Maximum apparent power at $\cos\varphi = 1$	5000 VA	6000 VA	8000 VA	10000 VA	12000 VA
Rated grid voltage	220 V / 380 V [3/N/PE] 230 V / 400 V [3/N/PE] 240 V / 415 V [3/N/PE]				
Grid voltage range	270-480 V (Phase to Phase)				
Rated grid frequency	50 Hz/60 Hz				
Grid frequency range	45-55 Hz/55-65 Hz				
Rated output current at 220 V	7.6 A	9.1 A	12.2 A	15.2 A	18.2 A
Rated output current at 230 V	7.3 A	8.7 A	11.6 A	14.5 A	17.4 A
Rated output current at 240 V	7.0 A	8.4 A	11.2 A	13.9 A	16.7 A
Maximum output current	8.0 A	9.6 A	12.8 A	16.0 A	19.2 A
Max. input power from grid	10000 W	12000 W	16000 W	20000 W	24000 W
Max. input current from grid	14.5 A	17.4 A	23.2 A	29.0 A	34.8 A
Inrush current	<20% of nominal AC current for a maximum of 10ms				
Contribution to peak short-circuit current $i_p$	60 A				
Initial short-circuit alternating current (Ik" first single period effective value)	8.0 A	9.6 A	12.8 A	16.0 A	19.2 A
Short circuit current continuous [ms] (max output fault current)	8.0 A	9.6 A	12.8 A	16.0 A	19.2 A
Recommended rated current of AC circuit Breaker	20.0 A	25.0 A	32.0 A	32.0 A	40.0 A
Total harmonic distortion of the output current with total harmonic distortion of	<3% (of nominal power)				

the AC voltage <2%, and AC power >50% of the rated power					
Adjustable displacement power factor	0.8 leading to 0.8 lagging				
Overtoltage category in accordance with IEC 60664-1	III				
Efficiency					
Maximum efficiency	98.0%	98.2%	98.4%	98.4%	98.4%
European weighted efficiency	97.2%	97.5%	97.9%	97.9%	97.9%
Battery data					
Max charging power	5000 W	6000 W	8000 W	10000 W	12000 W
Max discharging power	5000 W	6000 W	8000 W	10000 W	12000 W
Battery voltage range	120~600 V				
Max charging current	30 A				
Max discharging current	30 A				
Rated charging current	30 A				
Rated discharging current	30 A				
Battery type	LiFePO4				
EPS load data					
Rated apparent power at 400V	5000 W	6000 W	8000 W	10000 W	12000 W
Max. apparent power at 400V, continuous on-grid	10000 VA	12000 VA	16000 VA	20000 VA	24000 VA
Max. apparent power at 400V continuous off-grid	5000 VA	6000 VA	8000 VA	10000 VA	12000 VA
Max. apparent power at at 400V, off-grid <10s	10000 VA	12000 VA	16000 VA	20000 VA	24000 VA
Max. power on each phase at 400V, continuous on-grid	3333 W	4000 W	5333 W	6667 W	8000 W
Max. power on each phase at 400V, continuous off-grid	1667 W	2000 W	2667 W	3333 W	4000 W
Nominal output voltage	220 V / 380 V [3/N/PE] 230 V / 400 V [3/N/PE] 240 V / 415 V [3/N/PE]				
AC grid frequency	50 Hz / 60 Hz				
Max. continuous output current	8.0 A	9.6 A	12.8 A	16.0 A	19.2 A
Max. output current < 10s	14.5 A	17.4 A	23.2 A	29.0 A	34.8 A
Rated current at 400V	7.3 A	8.7 A	11.6 A	14.5 A	17.4 A
Max. current at 400V, continuous on-grid	14.6 A	17.4 A	23.2 A	29.0 A	34.8 A
Max. current at 400V, continuous off-grid	7.3 A	8.7 A	11.6 A	14.5 A	17.4 A
Total harmonic distortion (THDv, linear load)	2%				
Switching time to battery-backup operation	<10 ms				

(1) The voltage range meets the requirements of the corresponding national grid code.

(2) The frequency range meets the requirements of the corresponding national grid code.

### 10.1.2 For Australian market

Type	ASW05kH -T2
DC Input	
Maximum power of PV array	7500 Wp
Max. power per MPP tracker	7500 W
Maximum input voltage	1100 V

Rated input voltage	630 V
Minimum input voltage	60 V
Start voltage	180 V
MPP voltage range	150-950 V
MPP voltage range at Pnom	250~850 V
Max. input current	20 A/20 A
Isc PV (absolute maximum)	30 A/30 A
Maximum reverse current into the PV modules	0 A
Number of independent MPP inputs	2
Strings per MPP input	PV1:1/PV2:1
Overvoltage category in accordance with ICE 60664-1	II
<b>AC Input and Output</b>	
Rated output power at 230 V	5000 W
Rated apparent power at $\cos\varphi = 1$	5000 VA
Maximum apparent power at $\cos\varphi = 1$	5000 VA
Rated grid voltage	220 V / 380 V [3/N/PE] 230 V / 400 V [3/N/PE] 240 V / 415 V [3/N/PE]
Grid voltage range	270-480 V (Phase to Phase)
Rated grid frequency	50 Hz/60 Hz
Grid frequency range	45-55 Hz/55-65 Hz
Rated output current at 220 V	7.6 A
Rated output current at 230 V	7.3 A
Rated output current at 240 V	7.0 A
Maximum output current	8.0 A
Max. input power from grid	10000 W
Max. input current from grid	14.5 A
Inrush current	<20% of nominal AC current for a maximum of 10ms
Contribution to peak short-circuit current $i_p$	60 A
Initial short-circuit alternating current ( $I_k$ " first single period effective value)	8.0 A
Short circuit current continuous [ms] (max output fault current)	8.0 A
Recommended rated current of AC circuit Breaker	20.0 A
Total harmonic distortion of the output current with total harmonic distortion of the AC voltage <2%, and AC power >50% of the rated power	<3% (of nominal power)
Adjustable displacement power factor	0.8 leading to 0.8 lagging
Overvoltage category in accordance with IEC 60664-1	III
<b>Efficiency</b>	
Maximum efficiency	98.0%
European weighted efficiency	97.2%
<b>Battery data</b>	
Max charging power	5000 W
Max discharging power	5000 W
Battery voltage range	120~600 V

Max charging current	30 A
Max discharging current	30 A
Rated charging current	30 A
Rated discharging current	30 A
Battery type	LiFePO4
EPS load data	
Rated apparent power at 400V	5000 W
Max. apparent power at 400V, continuous on-grid	10000 VA
Max. apparent power at 400V continuous off-grid	5000 VA
Max. apparent power at at 400V, off-grid <10s	10000 VA
Max. power on each phase at 400V, continuous on-grid	3333 W
Max. power on each phase at 400V, continuous off-grid	1667 W
Nominal output voltage	220 V / 380 V [3/N/PE] 230 V / 400 V [3/N/PE] 240 V / 415 V [3/N/PE]
AC grid frequency	50 Hz / 60 Hz
Max. continuous output current	8.0 A
Max. output current < 10s	14.5 A
Rated current at 400V	7.3 A
Max. current at 400V, continuous on-grid	14.6 A
Max. current at 400V, continuous off-grid	7.3 A
Total harmonic distortion (THDv, linear load)	2%
Switching time to battery-backup operation	<10 ms

(1) The voltage range meets the requirements of the corresponding national grid code.

(2) The frequency range meets the requirements of the corresponding national grid code.

## 10.2 ASW05kH/06kH/08kH/10kH/12kH-T2-O

### 10.2.1 For European market

Type	ASW05kH -T2- ○	ASW06kH -T2- ○	ASW08kH -T2- ○	ASW10kH -T2- ○	ASW12kH -T2- ○
DC Input					
Maximum power of PV array	7500 Wp	9000 Wp	12000 Wp	15000 Wp	18000 Wp
Max. power per MPP tracker	7500 W	9000 W	10000 W	10000 W	10000 W
Maximum input voltage	1100 V				
Rated input voltage	630 V				
Minimum input voltage	60 V				
Start voltage	180 V				
MPP voltage range	150-950 V	150-950 V	200-950 V	200-950 V	200-950 V
MPP voltage range at Phom	250~850 V	290~850 V	350-850 V	380-850 V	450-850 V
Max. input current	20 A/20 A				
Isc PV (absolute maximum)	30 A/30 A				
Maximum reverse current into the PV modules	0 A				

Number of independent MPP inputs	2				
Strings per MPP input	PV1:1/PV2:1				
Overtoltage category in accordance with IEC 60664-1	II				
<b>AC Input and Output</b>					
Rated output power at 230 V	5000 W	6000 W	8000 W	10000 W	12000 W
Rated apparent power at $\cos\varphi = 1$	5000 VA	6000 VA	8000 VA	10000 VA	12000 VA
Maximum apparent power at $\cos\varphi = 1$	5000 VA	6000 VA	8000 VA	10000 VA	12000 VA
Rated grid voltage	220 V / 380 V [3/N/PE] 230 V / 400 V [3/N/PE] 240 V / 415 V [3/N/PE]				
Grid voltage range	270-480 V (Phase to Phase)				
Rated grid frequency	50Hz/60Hz				
Grid frequency range	45-55Hz/55-65Hz				
Rated output current at 220 V	7.6 A	9.1 A	12.2 A	15.2 A	18.2 A
Rated output current at 230 V	7.3 A	8.7 A	11.6 A	14.5 A	17.4 A
Rated output current at 240 V	7.0 A	8.4 A	11.2 A	13.9 A	16.7 A
Maximum output current	8.0 A	9.6 A	12.8 A	16.0 A	19.2 A
Max. input power from grid	5000 W	6000 W	8000 W	10000 W	12000 W
Max. input current from grid	8.0 A	9.6 A	12.8 A	16.0 A	19.2 A
Inrush current	<20% of nominal AC current for a maximum of 10ms				
Contribution to peak short-circuit current $i_p$	60 A				
Initial short-circuit alternating current ( $I_k$ " first single period effective value)	8.0 A	9.6 A	12.8 A	16.0 A	19.2 A
Short circuit current continuous [ms] (max output fault current)	8.0 A	9.6 A	12.8 A	16.0 A	19.2 A
Recommended rated current of AC circuit Breaker	16.0 A	16.0 A	16.0 A	20.0 A	25.0 A
Total harmonic distortion of the output current with total harmonic distortion of the AC voltage <2%, and AC power >50% of the rated power	<3% (of nominal power)				
Adjustable displacement power factor	0.8 leading to 0.8 lagging				
Overtoltage category in accordance with IEC 60664-1	III				
<b>Efficiency</b>					
Maximum efficiency	98.0%	98.2%	98.4%	98.4%	98.4%
European weighted efficiency	97.2%	97.5%	97.9%	97.9%	97.9%
<b>Battery data</b>					
Max charging power	5000 W	6000 W	8000 W	10000 W	12000 W
Max discharging power	5000 W	6000 W	8000 W	10000 W	12000 W
Battery voltage range	120-600 V				
Max charging current	30 A				
Max discharging current	30 A				
Rated charging current	30 A				
Rated discharging current	30 A				
Battery type	LiFePO4				

(1) The voltage range meets the requirements of the corresponding national grid code.

(2) The frequency range meets the requirements of the corresponding national grid code.

## 10.2.2 For Australian market

Type	ASW05kH -T2-O
<b>DC Input</b>	
Maximum power of PV array	7500 Wp
Max. power per MPP tracker	7500 W
Maximum input voltage	1100 V
Rated input voltage	630 V
Minimum input voltage	60 V
Start voltage	180 V
MPP voltage range	150-950 V
MPP voltage range at P <sub>nom</sub>	250-850 V
Max. input current	20 A/20 A
I <sub>sc</sub> PV (absolute maximum)	30 A/30 A
Maximum reverse current into the PV modules	0 A
Number of independent MPP inputs	2
Strings per MPP input	PV1:1/PV2:1
Overvoltage category in accordance with ICE 60664-1	II
<b>AC Input and Output</b>	
Rated output power at 230 V	5000 W
Rated apparent power at $\cos\varphi = 1$	5000 VA
Maximum apparent power at $\cos\varphi = 1$	5000 VA
Rated grid voltage	220 V / 380 V [3/N/PE] 230 V / 400 V [3/N/PE] 240 V / 415 V [3/N/PE]
Grid voltage range	270-480 V (Phase to Phase)
Rated grid frequency	50Hz/60Hz
Grid frequency range	45-55Hz/55-65Hz
Rated output current at 220 V	7.6 A
Rated output current at 230 V	7.3 A
Rated output current at 240 V	7.0 A
Maximum output current	8.0 A
Max. input power from grid	5000 W
Max. input current from grid	8.0 A
Inrush current	<20% of nominal AC current for a maximum of 10ms
Contribution to peak short-circuit current $i_p$	60 A
Initial short-circuit alternating current ( $I_k$ " first single period effective value)	8.0 A
Short circuit current continuous [ms] (max output fault current)	8.0 A
Recommended rated current of AC circuit Breaker	16.0 A
Total harmonic distortion of the output current with total harmonic distortion of the AC voltage <2%, and AC power >50% of the rated power	<3% (of nominal power)
Adjustable displacement power factor	0.8 leading to 0.8 lagging
Overvoltage category in accordance with IEC 60664-1	III

Efficiency	
Maximum efficiency	98.0%
European weighted efficiency	97.2%
Battery data	
Max charging power	5000 W
Max discharging power	5000 W
Battery voltage range	120~600 V
Max charging current	30 A
Max discharging current	30 A
Rated charging current	30 A
Rated discharging current	30 A
Battery type	LiFePO4

(1) The voltage range meets the requirements of the corresponding national grid code.

(2) The frequency range meets the requirements of the corresponding national grid code.

## 10.3 ASW08kH/10kH/12kH-T3

### 10.3.1 For European market

Type	ASW08kH -T3	ASW10kH -T3	ASW12kH -T3
DC Input			
Maximum power of PV array	12000 Wp	15000 Wp	18000 Wp
Max. power per MPP tracker	10000 W	10000 W	10000 W
Maximum input voltage	1100 V		
Rated input voltage	630 V		
Minimum input voltage	60 V		
Start voltage	180 V		
MPP voltage range	200-950 V	200-950 V	200-950 V
MPP voltage range at Pnom	250-850 V	320-850 V	380-850 V
Max. input current	16 A/16 A/16 A		
Isc PV (absolute maximum)	24 A/24 A/24 A		
Maximum reverse current into the PV modules	0 A		
Number of independent MPP inputs	3		
Strings per MPP input	PV1:1/PV2:1/PV3:1		
Overvoltage category in accordance with ICE 60664-1	II		
AC Input and Output			
Rated output power at 230 V	8000 W	10000 W	12000 W
Rated apparent power at $\cos\varphi = 1$	8000 VA	10000 VA	12000 VA
Maximum apparent power at $\cos\varphi = 1$	8000 VA	10000 VA	12000 VA
Rated grid voltage	220 V / 380 V [3/N/PE] 230 V / 400 V [3/N/PE] 240 V / 415 V [3/N/PE]		
Grid voltage range	270-480 V (Phase to Phase)		
Rated grid frequency	50 Hz/60 Hz		
Grid frequency range	45-55 Hz/55-65 Hz		
Rated output current at 220 V	12.2 A	15.2 A	18.2 A



Rated output current at 230 V	11.6 A	14.5 A	17.4 A
Rated output current at 240 V	11.2 A	13.9 A	16.7 A
Maximum output current	12.8 A	16.0 A	19.2 A
Max. input power from grid	16000 W	20000 W	24000 W
Max. input current from grid	23.2 A	29.0 A	34.8 A
Inrush current	<20% of nominal AC current for a maximum of 10ms		
Contribution to peak short-circuit current $i_p$	60 A		
Initial short-circuit alternating current ( $I_k$ " first single period effective value)	12.8 A	16.0 A	19.2 A
Short circuit current continuous [ms] (max output fault current)	12.8 A	16.0 A	19.2 A
Recommended rated current of AC circuit Breaker	32.0 A	32.0 A	40.0 A
Total harmonic distortion of the output current with total harmonic distortion of the AC voltage <2%, and AC power >50% of the rated power	<3% (of nominal power)		
Adjustable displacement power factor	0.8 leading to 0.8 lagging		
Overvoltage category in accordance with IEC 60664-1	III		
<b>Efficiency</b>			
Maximum efficiency	98.4%	98.4%	98.4%
European weighted efficiency	97.9%	97.9%	97.9%
<b>Battery data</b>			
Max charging power	8000 W	10000 W	12000 W
Max discharging power	8000 W	10000 W	12000 W
Battery voltage range	120~600 V		
Max charging current	30 A		
Max discharging current	30 A		
Rated charging current	30 A		
Rated discharging current	30 A		
Battery type	LiFePO4		
<b>EPS load data</b>			
Rated apparent power at 400V	8000 W	10000 W	12000 W
Max. apparent power at 400V, continuous on-grid	16000 VA	20000 VA	24000 VA
Max. apparent power at 400V continuous off-grid	8000 VA	10000 VA	12000 VA
Max. apparent power at at 400V, off-grid <10s	16000 VA	20000 VA	24000 VA
Max. power on each phase at 400V, continuous on-grid	5333 W	6667 W	8000 W
Max. power on each phase at 400V, continuous off-grid	2667 W	3333 W	4000 W
Nominal AC voltage	230 V / 400 V [3/N/PE]		
AC grid frequency	50 Hz / 60 Hz		
Max. continuous output current	12.8 A	16.0 A	19.2 A
Max. output current < 10s	23.2 A	29.0 A	34.8 A
Rated current at 400V	11.6 A	14.5 A	17.4 A
Max. current at 400V, continuous on-grid	23.2 A	29.0 A	34.8 A

Max. current at 400V, continuous off-grid	11.6 A	14.5 A	17.4 A
Total harmonic distortion (THDv, linear load)	2%		
Switching time to battery-backup operation	<10 ms		

(1) The voltage range meets the requirements of the corresponding national grid code.

(2) The frequency range meets the requirements of the corresponding national grid code.

### 10.3.2 For Australian market

Type	ASW08kH -T3	ASW10kH -T3	ASW12kH -T3
<b>DC Input</b>			
Maximum power of PV array	12000 Wp	15000 Wp	18000 Wp
Max. power per MPP tracker	10000 W	10000 W	10000 W
Maximum input voltage	1100 V		
Rated input voltage	630 V		
Minimum input voltage	60 V		
Start voltage	180 V		
MPP voltage range	200-950 V	200-950 V	200-950 V
MPP voltage range at Pnom	250-850 V	320-850 V	380-850 V
Max. input current	16 A/16 A/16 A		
Isc PV (absolute maximum)	24 A/24 A/24 A		
Maximum reverse current into the PV modules	0 A		
Number of independent MPP inputs	3		
Strings per MPP input	PV1:1/PV2:1/PV3:1		
Overvoltage category in accordance with ICE 60664-1	II		
<b>AC Input and Output</b>			
Rated output power at 230 V	8000 W	9999 W	12000 W
Rated apparent power at $\cos\varphi = 1$	8000 VA	9999 VA	12000 VA
Maximum apparent power at $\cos\varphi = 1$	8000 VA	9999 VA	12000 VA
Rated grid voltage	220 V / 380 V [3/N/PE] 230 V / 400 V [3/N/PE] 240 V / 415 V [3/N/PE]		
Grid voltage range	270-480 V (Phase to Phase)		
Rated grid frequency	50 Hz/60 Hz		
Grid frequency range	45-55 Hz/55-65 Hz		
Rated output current at 220 V	12.2 A	15.2 A	18.2 A
Rated output current at 230 V	11.6 A	14.5 A	17.4 A
Rated output current at 240 V	11.2 A	13.9 A	16.7 A
Maximum output current	12.8 A	16.0 A	19.2 A
Max. input power from grid	16000 W	20000 W	24000 W
Max. input current from grid	23.2 A	29.0 A	34.8 A
Inrush current	<20% of nominal AC current for a maximum of 10ms		
Contribution to peak short-circuit current ip	60 A		
Initial short-circuit alternating current (Ik" first single period effective value)	12.8 A	16.0 A	19.2 A
Short circuit current continuous [ms] (max output fault current)	12.8 A	16.0 A	19.2 A
Recommended rated current of AC circuit Breaker	32.0 A	32.0 A	40.0 A

Total harmonic distortion of the output current with total harmonic distortion of the AC voltage <2%, and AC power >50% of the rated power	<3% (of nominal power)		
Adjustable displacement power factor	0.8 leading to 0.8 lagging		
Overtoltage category in accordance with IEC 60664-1	III		
<b>Efficiency</b>			
Maximum efficiency	98.4%	98.4%	98.4%
European weighted efficiency	97.9%	97.9%	97.9%
<b>Battery data</b>			
Max charging power	8000 W	10000 W	12000 W
Max discharging power	8000 W	10000 W	12000 W
Battery voltage range	120~600 V		
Max charging current	30 A		
Max discharging current	30 A		
Rated charging current	30 A		
Rated discharging current	30 A		
Battery type	LiFePO4		
<b>EPS load data</b>			
Rated apparent power at 400V	8000 W	9999 W	12000 W
Max. apparent power at 400V, continuous on-grid	16000 VA	19998 VA	24000 VA
Max. apparent power at 400V continuous off-grid	8000 VA	9999 VA	12000 VA
Max. apparent power at at 400V, off-grid <10s	16000 VA	19998 VA	24000 VA
Max. power on each phase at 400V, continuous on-grid	5333 W	6666 W	8000 W
Max. power on each phase at 400V, continuous off-grid	2667 W	3333 W	4000 W
Nominal AC voltage	230 V / 400 V [3/N/PE]		
AC grid frequency	50 Hz / 60 Hz		
Max. continuous output current	12.8 A	16.0 A	19.2 A
Max. output current < 10s	23.2 A	29.0 A	34.8 A
Rated current at 400V	11.6 A	14.5 A	17.4 A
Max. current at 400V, continuous on-grid	23.2 A	29.0 A	34.8 A
Max. current at 400V, continuous off-grid	11.6 A	14.5 A	17.4 A
Total harmonic distortion (THDv, linear load)	2%		
Switching time to battery-backup operation	<10 ms		

(1) The voltage range meets the requirements of the corresponding national grid code.

(2) The frequency range meets the requirements of the corresponding national grid code.

## 10.4 ASW08kH/10kH/12kH-T3-O

### 10.4.1 For European market

Type	ASW08kH -T3-O	ASW10kH -T3-O	ASW12kH -T3-O
DC Input			

Maximum power of PV array	12000 Wp	15000 Wp	18000 Wp
Max. power per MPP tracker	10000 W	10000 W	10000 W
Maximum input voltage	1100 V		
Rated input voltage	630 V		
Minimum input voltage	60 V		
Start voltage	180 V		
MPP voltage range	200-950 V	200-950 V	200-950 V
MPP voltage range at Phom	250-850 V	320-850 V	380-850 V
Max. input current	16A/16A/16A		
Isc PV (absolute maximum)	24A/24A/24A		
Maximum reverse current into the PV modules	0 A		
Number of independent MPP inputs	3		
Strings per MPP input	PV1:1/PV2:1/PV3:1		
Overvoltage category in accordance with ICE 60664-1	II		
<b>AC Input and Output</b>			
Rated output power at 230 V	8000 W	10000 W	12000 W
Rated apparent power at $\cos\varphi = 1$	8000 VA	10000 VA	12000 VA
Maximum apparent power at $\cos\varphi = 1$	8000 VA	10000 VA	12000 VA
Rated grid voltage	220 V / 380 V [3/N/PE] 230 V / 400 V [3/N/PE] 240 V / 415 V [3/N/PE]		
Grid voltage range	270-480 V (Phase to Phase)		
Rated grid frequency	50Hz/60Hz		
Grid frequency range	45-55Hz/55-65Hz		
Rated output current at 220 V	12.2 A	15.2 A	18.2 A
Rated output current at 230 V	11.6 A	14.5 A	17.4 A
Rated output current at 240 V	11.2 A	13.9 A	16.7 A
Maximum output current	12.8 A	16.0 A	19.2 A
Max. input power from grid	8000 W	10000 W	12000 W
Max. input current from grid	12.8 A	16.0 A	19.2 A
Inrush current	<20% of nominal AC current for a maximum of 10ms		
Contribution to peak short-circuit current $i_p$	60 A		
Initial short-circuit alternating current ( $I_k$ " first single period effective value)	12.8 A	16.0 A	19.2 A
Short circuit current continuous [ms] (max output fault current)	12.8 A	16.0 A	19.2 A
Recommended rated current of AC circuit Breaker	16.0 A	20.0 A	25.0 A
Total harmonic distortion of the output current with total harmonic distortion of the AC voltage <2%, and AC power >50% of the rated power	<3% (of nominal power)		
Adjustable displacement power factor	0.8 leading to 0.8 lagging		
Overvoltage category in accordance with IEC 60664-1	III		
<b>Efficiency</b>			
Maximum efficiency	98.4%	98.4%	98.4%
European weighted efficiency	97.9%	97.9%	97.9%
<b>Battery data</b>			

Max charging power	8000 W	10000 W	12000 W
Max discharging power	8000 W	10000 W	12000 W
Battery voltage range	120~600 V		
Max charging current	30 A		
Max discharging current	30 A		
Rated charging current	30 A		
Rated discharging current	30 A		
Battery type	LiFePO4		

(1) The voltage range meets the requirements of the corresponding national grid code.

(2) The frequency range meets the requirements of the corresponding national grid code.

### 10.3.2 For Australian market

Type	ASW08kH -T3-O	ASW10kH -T3-O	ASW12kH -T3-O
<b>DC Input</b>			
Maximum power of PV array	12000 Wp	15000 Wp	18000 Wp
Max. power per MPP tracker	10000 W	10000 W	10000 W
Maximum input voltage	1100 V		
Rated input voltage	630 V		
Minimum input voltage	60 V		
Start voltage	180 V		
MPP voltage range	200-950 V	200-950 V	200-950 V
MPP voltage range at Pnom	250-850 V	320-850 V	380-850 V
Max. input current	16A/16A/16A		
Isc PV (absolute maximum)	24A/24A/24A		
Maximum reverse current into the PV modules	0 A		
Number of independent MPP inputs	3		
Strings per MPP input	PV1:1/PV2:1/PV3:1		
Overvoltage category in accordance with ICE 60664-1	II		
<b>AC Input and Output</b>			
Rated output power at 230 V	8000 W	9999 W	12000 W
Rated apparent power at $\cos\varphi = 1$	8000 VA	9999 VA	12000 VA
Maximum apparent power at $\cos\varphi = 1$	8000 VA	9999 VA	12000 VA
Rated grid voltage	220 V / 380 V [3/N/PE] 230 V / 400 V [3/N/PE] 240 V / 415 V [3/N/PE]		
Grid voltage range	270-480 V (Phase to Phase)		
Rated grid frequency	50Hz/60Hz		
Grid frequency range	45-55Hz/55-65Hz		
Rated output current at 220 V	12.2 A	15.2 A	18.2 A
Rated output current at 230 V	11.6 A	14.5 A	17.4 A
Rated output current at 240 V	11.2 A	13.9 A	16.7 A
Maximum output current	12.8 A	16.0 A	19.2 A
Max. input power from grid	8000 W	10000 W	12000 W
Max. input current from grid	12.8 A	16.0 A	19.2 A
Inrush current	<20% of nominal AC current for a maximum of 10ms		

Contribution to peak short-circuit current $i_p$	60 A		
Initial short-circuit alternating current ( $I_k$ " first single period effective value)	12.8 A	16.0 A	19.2 A
Short circuit current continuous [ms] (max output fault current)	12.8 A	16.0 A	19.2 A
Recommended rated current of AC circuit Breaker	16.0 A	20.0 A	25.0 A
Total harmonic distortion of the output current with total harmonic distortion of the AC voltage <2%, and AC power >50% of the rated power	<3% (of nominal power)		
Adjustable displacement power factor	0.8 leading to 0.8 lagging		
Overvoltage category in accordance with IEC 60664-1	III		
<b>Efficiency</b>			
Maximum efficiency	98.4%	98.4%	98.4%
European weighted efficiency	97.9%	97.9%	97.9%
<b>Battery data</b>			
Max charging power	8000 W	10000 W	12000 W
Max discharging power	8000 W	10000 W	12000 W
Battery voltage range	120~600 V		
Max charging current	30 A		
Max discharging current	30 A		
Rated charging current	30 A		
Rated discharging current	30 A		
Battery type	LiFePO4		

(1) The voltage range meets the requirements of the corresponding national grid code.

(2) The frequency range meets the requirements of the corresponding national grid code.

## 10.5 General data

Type	ASW05kH/06kH/08kH/10kH/12kH-T2 ASW05kH/06kH/08kH/10kH/12kH-T2-O	ASW08kH/10kH/12kH-T3 ASW08kH/10kH/12kH-T3-O
Width x height x depth	545 mm x 465 mm x 205 mm	
Weight	24.5 kg	26 kg
Topology	Non-isolated	
Operating temperature range	-25°C ... +60°C	
Allowable relative humidity range (non-condensing)	0% ... 100%	
Degree of protection for electronics in accordance with IEC 60529	IP66	
Climatic category in accordance with IEC 60721-3-4	4K4H	
Protection class (according to IEC 62103)	I	
Pollution degree outside the enclosure	3	
Pollution degree inside the enclosure	2	
Max. operating altitude above mean sea level	4000 m (>3000 m derating)	
Self-consumption (night)	<10W	
Cooling method	Natural convection	

Typical noise emission	< 30 dB(A)@1m	
Display	LED indicator, App	
Demand response mode in accordance with AS/NZS 4777.2	DRM0	
Export active power output	Via connecting Smart meter	
Earth Fault Alarm	cloud based, Visible	
Interfaces	RS485, WiFi stick	
Communication	ModBus RTU and CAN	
Mounting information	Wall mounting bracket	
Radio technology	WLAN 802.11 b/g/n	
Radio spectrum	2.4 GHz	
Maximum transmission power	100 mW	
AFCI type	F-I-AFPE-1-1-2	F-I-AFPE-1-1-3

## 10.6 Protective function

Protective function	ASW05kH/06kH/08kH/10kH/12kH-T2 ASW05kH/06kH/08kH/10kH/12kH-T2-O ASW08kH/10kH/12kH-T3 ASW08kH/10kH/12kH-T3-O
DC reverse polarity protection	Integrated
DC isolator	Integrated
Ground fault monitoring	Integrated
AC short- circuit current capability	Integrated
Active anti-islanding protection	Integrated
PV string current monitoring	Integrated
DC current injection monitoring	Integrated
Low voltage ride through	Integrated
High voltage ride through	Integrated
Overvoltage protection	DC Type II / AC Type III

## 11 Troubleshooting

When the PV system does not operate normally, we recommend the following solutions for quick troubleshooting. If an error or warning occurs, there will have "Event Messages" display in the LCD screen and monitor tools. The corresponding corrective measures are as follows:

Error code	Message	Corrective measures
1-6 8,9	Permanent Fault	<ul style="list-style-type: none"> <li>• Disconnect the inverter from the battery, the grid and the PV array and reconnect after 3 minutes.</li> <li>• If this fault is still being shown, contact the service.</li> <li>• The inverter temperature should above -40°C.</li> </ul>
10	Device fault	<ul style="list-style-type: none"> <li>• Disconnect the inverter from the battery, the grid and the PV array and reconnect after 3 minutes.</li> <li>• If this fault is still being shown, contact the service.</li> <li>• The inverter temperature should above -40°C.</li> </ul>
32	Abnormal frequency change	<ul style="list-style-type: none"> <li>• Check if the grid is abnormal.</li> <li>• Restart the inverter and wait until it functions normally.</li> <li>• Contact customer service if error warning continues.</li> </ul>
33	Grid frequency fault	<ul style="list-style-type: none"> <li>• Check the grid and EPS frequency and observe how often major fluctuations occur.</li> <li>• Contact customer service if EPS frequency abnormal.</li> <li>• If this fault is caused by frequent fluctuations, try to modify the operating parameters after informing the grid operator first.</li> </ul>
34	Grid voltage fault	<ul style="list-style-type: none"> <li>• Check the grid voltage and grid connection on inverter.</li> <li>• Check the grid voltage at the point of connection of inverter.</li> <li>• If the grid voltage is outside the permissible range due to local grid conditions, try to modify the values of the monitored operational limits after informing the electric utility company first.</li> <li>• If the grid voltage lies within the permitted range and this fault still occurs, please call service.</li> </ul>
35	Grid loss	<ul style="list-style-type: none"> <li>• Check the fuse and the triggering of the circuit breaker in the distribution box.</li> <li>• Check the grid voltage, grid usability.</li> <li>• Check the AC cable, grid connection on the inverter.</li> <li>• If this fault is still being shown, contact the service.</li> </ul>
36	GFCI fault	<ul style="list-style-type: none"> <li>• Make sure the grounding connection of the inverter is reliable.</li> <li>• Make a visual inspection of all PV cables and modules.</li> <li>• If this fault is still shown, contact the service.</li> </ul>
37	PV over voltage fault	<ul style="list-style-type: none"> <li>• Check the open-circuit voltages of the strings and make sure it is below the maximum DC input voltage of the inverter.</li> <li>• If the input voltage lies within the permitted range and the fault still occurs, please call service.</li> </ul>
38	Isolation fault	<ul style="list-style-type: none"> <li>• Check the PV array's insulation to ground and make sure that the insulation resistance to ground is greater than 1 Mohm. Otherwise, make a visual inspection of all PV cables and modules.</li> <li>• Make sure the grounding connection of the inverter is reliable.</li> <li>• If this fault occurs often, contact the service.</li> </ul>
40	Over temperature fault	<ul style="list-style-type: none"> <li>• Check whether the airflow to the heat sink is obstructed.</li> <li>• Check whether the ambient temperature around the inverter is too high.</li> </ul>
41,42	Self-diagnosis	<ul style="list-style-type: none"> <li>• Disconnect the inverter from the battery, the grid and the PV array and reconnect</li> </ul>



	fault	<p>after 3 minutes.</p> <ul style="list-style-type: none"> <li>• If this fault is still being shown, contact the service.</li> </ul>
46	Bus over voltage	<ul style="list-style-type: none"> <li>• Check the input mode setting is correct.</li> <li>• Restart the inverter and wait until it functions normally.</li> <li>• Contact customer service if error warning continues.</li> </ul>
48	10 minutes average over voltage fault	<ul style="list-style-type: none"> <li>• Check the grid voltage at the point of connection of inverter.</li> <li>• If the grid voltage is outside the permissible range due to local grid conditions, try to modify the values of the monitored operational limits after informing the electric utility company first.</li> <li>• If the grid voltage lies within the permitted range and this fault still occurs, please call service.</li> </ul>
65	PE wire connection fault	<ul style="list-style-type: none"> <li>• Check if the ground line is connected with the inverter;</li> <li>• Make sure the grounding connection of the inverter is connected and reliable.</li> <li>• If this fault occurs often, contact the service.</li> </ul>
72	Parallel RS 485 Comm Fault	<ul style="list-style-type: none"> <li>• Check comm line and 120ohm Resistors.</li> </ul>
73	Parallel CAN Comm Fault	<ul style="list-style-type: none"> <li>• Check comm line and 120ohm Resistors.</li> </ul>
79	Parallel Multiple Host Fault	<ul style="list-style-type: none"> <li>• Check host quantity and set one host.</li> </ul>

Contact the service if you meet other problems not in the table.

## 12 Maintenance

### 12.1 Cleaning the contacts of the DC switch

#### **DANGER**

High voltage of PV string may cause life danger!

If the DC connector is disconnected while the PV inverter is working, electric arc may occur, causing electric shock and burns.

Please disconnect the circuit breaker on the AC side first, and then disconnect the DC switch.

To ensure the normal operation of the DC input switch, it is necessary to clean the DC switch contacts every year.

#### **Procedure:**

**Step 1:** Disconnect the AC disconnecter and prevent accidental restart.

**Step 2:** Rotate the DC switch handle from the “ON” position to the “OFF” position for 5 times.

### 12.2 Cleaning air inlet and outlet

#### **CAUTION**

Hot enclosure or heat sink may cause personal injury!

When the inverter is working, the temperature of the enclosure or heat sink will be higher than 70°C, and the contact may cause burns.

Before cleaning the air outlet, shut down the machine and wait for about 30 minutes until the temperature of the enclosure decreases to normal temperature.

A huge amount of heat is generated in the process of running the inverter. The inverter adopts a controlled forced-air cooling method. In order to maintain good ventilation, please check to make sure the air inlet and outlet are not blocked.

#### **Procedure:**

**Step 1:** Disconnect the AC side circuit breaker and ensure that it cannot be accidentally reconnected.

**Step 2:** Disconnect the DC switch, rotate the DC switch handle from the “ON” position to the “OFF” position.

**Step 3:** Clean the air inlet and outlet of the inverter with a soft brush.

## 13 Recycling and disposal

Dispose of the packaging and replaced parts according to the rules applicable in the country where the device is installed.



Do not dispose of the product together with the household waste but in accordance with the disposal regulations for electronic waste applicable at the installation site.

## 14 EU declaration of conformity

Within the scope of the EU directives

- Radio Equipment Directive 2014/53/EU (L 153/62-106. May 22. 2014) (RED)
- Restriction of the use of certain hazardous substances 2011/65/EU (L 174/88, June 8, 2011) and 2015/863/EU (L 137/10, March 31,2015) (RoHS)



AISWEI Technology Co., Ltd. confirms herewith that the inverters described in this manual are in compliance with the fundamental requirements and other relevant provisions of the above mentioned directives.

The entire EU Declaration of Conformity can be found at [www.solplanet.net](http://www.solplanet.net).

## 15 Service and warranty

If you have any technical problems concerning our products, please contact Solplanet service. We require the following information in order to provide you with the necessary assistance:

- Inverter device type
- Inverter serial number
- Type and number of connected PV modules
- Error code
- Mounting location
- Installation date
- Warranty card

Warranty terms and conditions can be downloaded at [www.solplanet.net](http://www.solplanet.net).

When the customer needs warranty service during the warranty period, the customer must provide a copy of the invoice, factory warranty card, and ensure the electrical label of the inverter is legible. If these conditions are not met, Solplanet has the right to refuse to provide with the relevant warranty service.

## 16 Contact

### EMEA

Service email: [service.EMEA@solplanet.net](mailto:service.EMEA@solplanet.net)

### APAC

Service email: [service.APAC@solplanet.net](mailto:service.APAC@solplanet.net)

### LATAM

Service email: [service.LATAM@solplanet.net](mailto:service.LATAM@solplanet.net)

### AISWEI Pty Ltd.

Hotline: +61 390 988 674

Add.: Level 40, 140 William Street, Melbourne VIC 3000, Australia

### AISWEI B.V.

Hotline: +31 208 004 844 (Netherlands)

+48 134 926 109 (Poland)

Add.: Barbara Strozilaan 101,5e etage,kantoornummer 5.12,1083HN Amsterdam,the Netherlands

### AISWEI Technology Co., Ltd

Hotline: +86 400 801 9996

Add.: Room 904 - 905, No. 757 Mengzi Road, Huangpu District, Shanghai 200023

<https://solplanet.net/contact-us/>

Scan QR code:



Android

Scan QR code:



iOS

